



PROCESS CONTROL SYSTEMS, INC.
327 LAKE HAZELTINE DRIVE, CHASKA, MN 55318

952-361-3026
(Fax) 952-368-4129
800-328-0738

MAXIGARD™



A1500GEC SPEED SWITCH SINGLE SET POINT - SELF CONTAINED

Introduction

The MAXIGARD A1500GEC is a single adjustable set point speed switch designed to monitor the rotation of critical driven shaft and indicate an under speed or over speed condition.

Principle of Operation

The A1500 Series speed switches are supplied with a non-contacting sensor and magnetic target. The sensor signal is not impaired by build-up of dust or any other foreign material on the magnet disc or sensing head. This switch is designed to detect under speed, over speed or stopping of the monitored shaft. The A1500 Series switch has one adjustable set point. The set point is designed fail-safe for under speed applications and in the event of a power failure, loss of signal, component failure etc., the relay will de-energize and put the switch into an alarm condition.

The A1500GEC set point relay has a built in power up time delay of approximately 7 seconds which allows machinery controlled through the motor starter circuit to reach the set point during start-up. The delay activates on power-up only.

Components

THE A1500GEC MOTION SWITCH INCLUDES:

- 4" MAGNET DISC
- SELF-CONTAINED SENSOR
- CALIBRATION/ RELAY CIRCUIT
- SWITCH HOUSING/ MOUNTING BRACKET

CALL TOLL FREE  800-328-0738

www.maxigard.com
E-mail: techsupport@maxigard.com

SECTION 1 - MECHANICAL

1.0 Magnet Disc

- 1.1 The end of the shaft to be monitored should be square to prevent excessive disc wobble.
- 1.2 Center drill and tap the shaft end. (Suggested #21 drill and #10-32NF tap). Bolt the magnet disc to the end of the shaft. Use "Loc-tite" to keep the bolt and disc tight on the shaft.
(see figure 1A, page 3).

2.0 Magnet Wrap (optional)

- 2.1 Separate the two halves of the magnet wrap by loosening the cap screws holding the two halves together.
- 2.2 Place both halves of the magnet wrap around the shaft. Re-insert and tighten the cap screws making sure the wrap is square to the shaft.
(see figure 1B, page 3).

NOTE

There will be a slight gap between the two halves after tightening. This gap will not affect the generated signal.

3.0 Mounting the Speed Switch

- 3.1 Place the switch so the sensor is centered directly in front of the magnets on the disc or optional wrap.
(see figure 1A & 1B, page 3).
- 3.2 The gap setting between the sensor and magnet disc should be approximately 1/8" - 7/8".

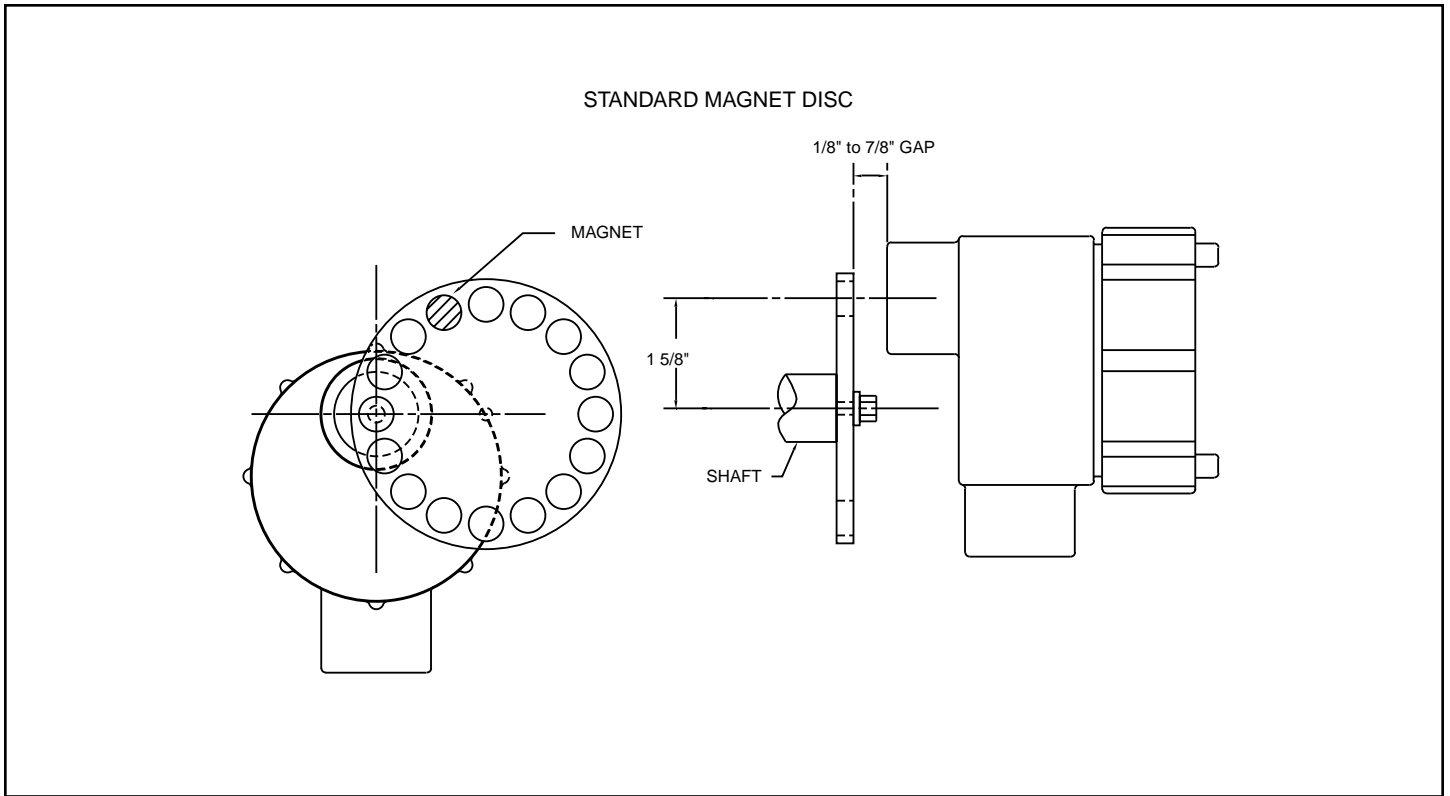

Figure 1A

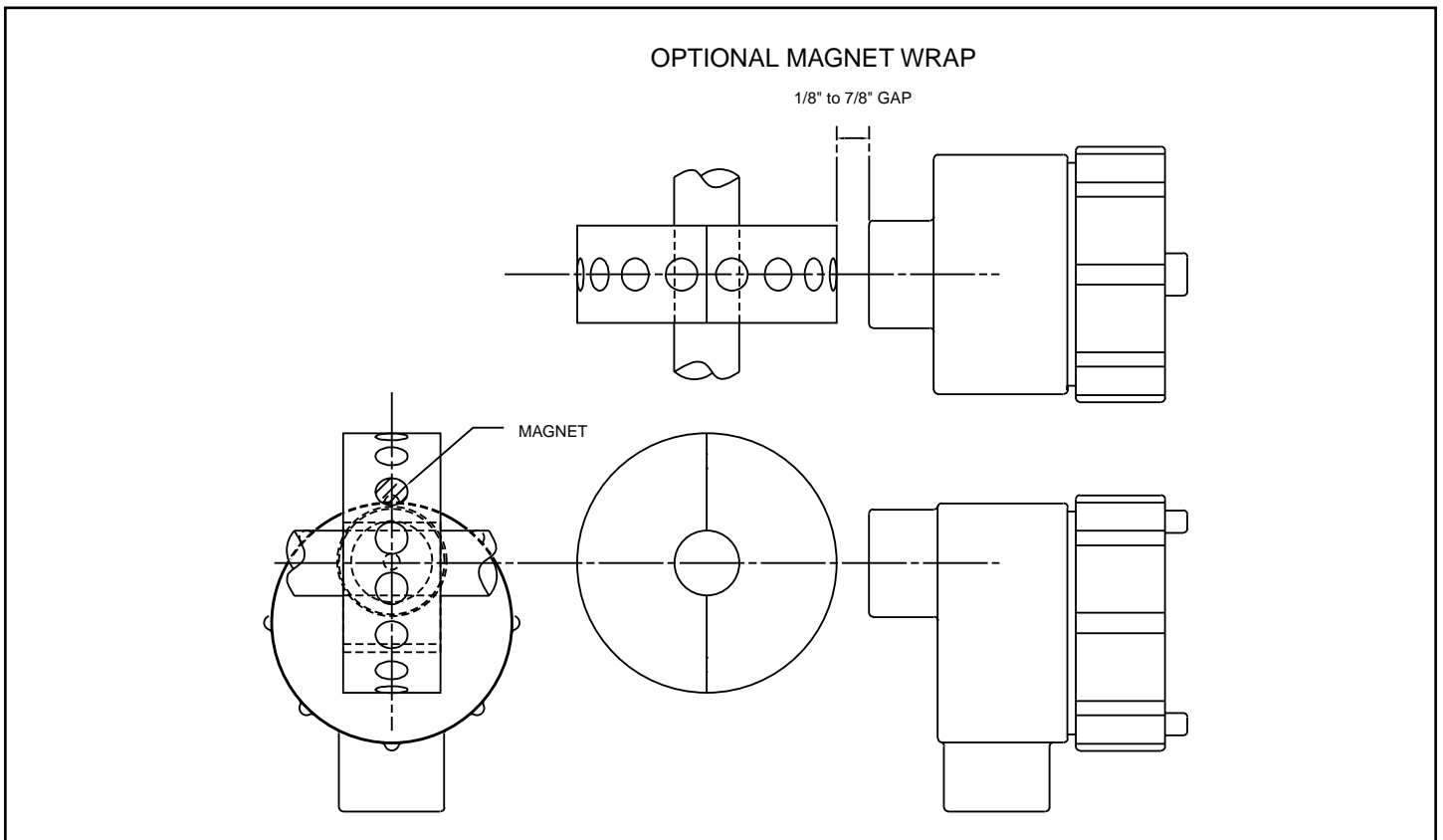

Figure 1B

4.0 SPEED SWITCH HOUSING

4.1 The A1500GEC switch enclosure is UL/CSA listed and certified for Class I, Div. 1 & 2, Group D, Class II Div. 1 & 2, Group E, F, & G, Class III. (see figure 2, page 4).

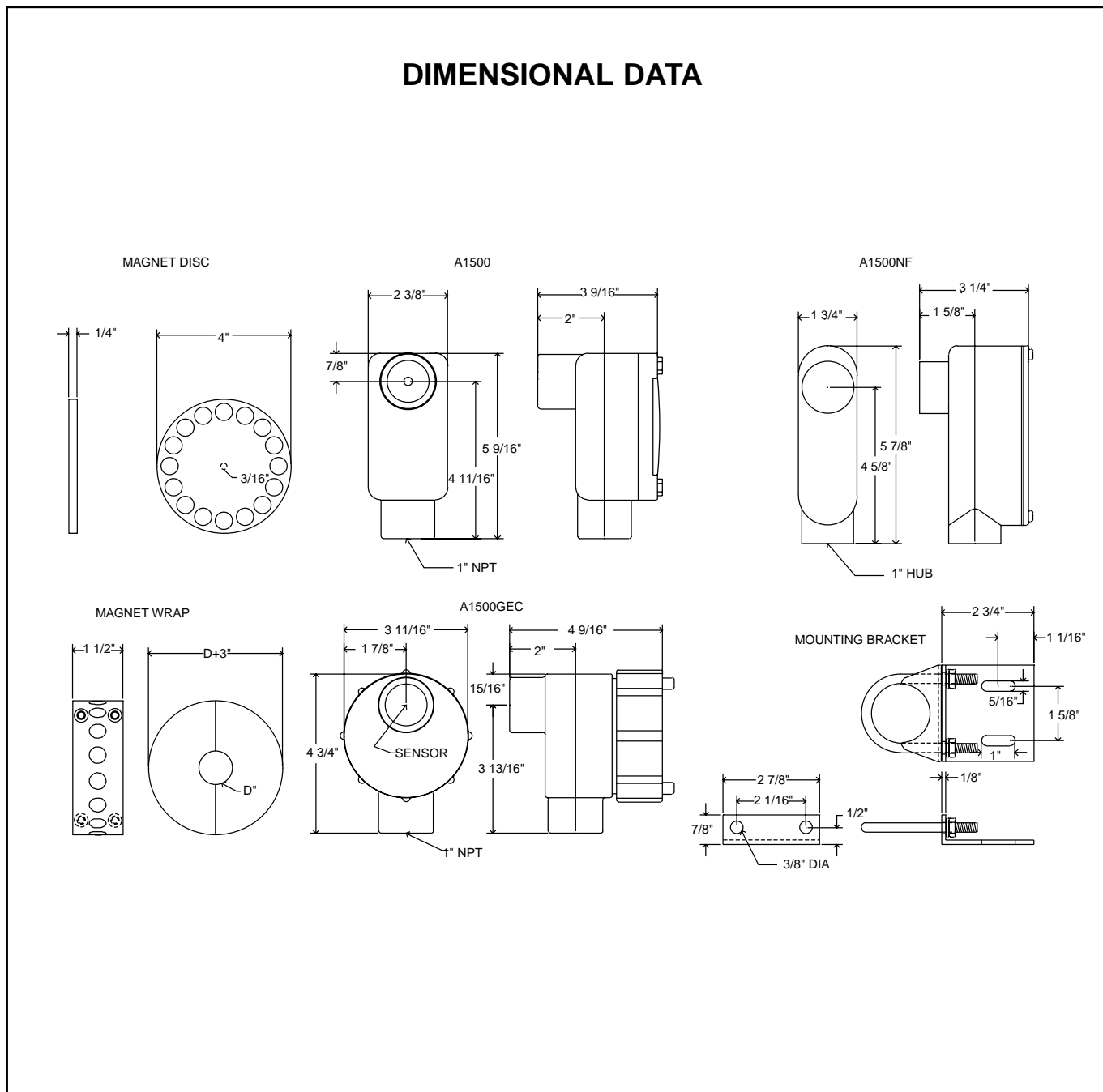

Figure 2

SECTION 2 - FIELD WIRING

5.0 Wiring the A1500GEC Speed Switch

- 5.1 Connect 120 VAC to L1 (red) and L2 (white, neutral).
(see figure 3, page 5).

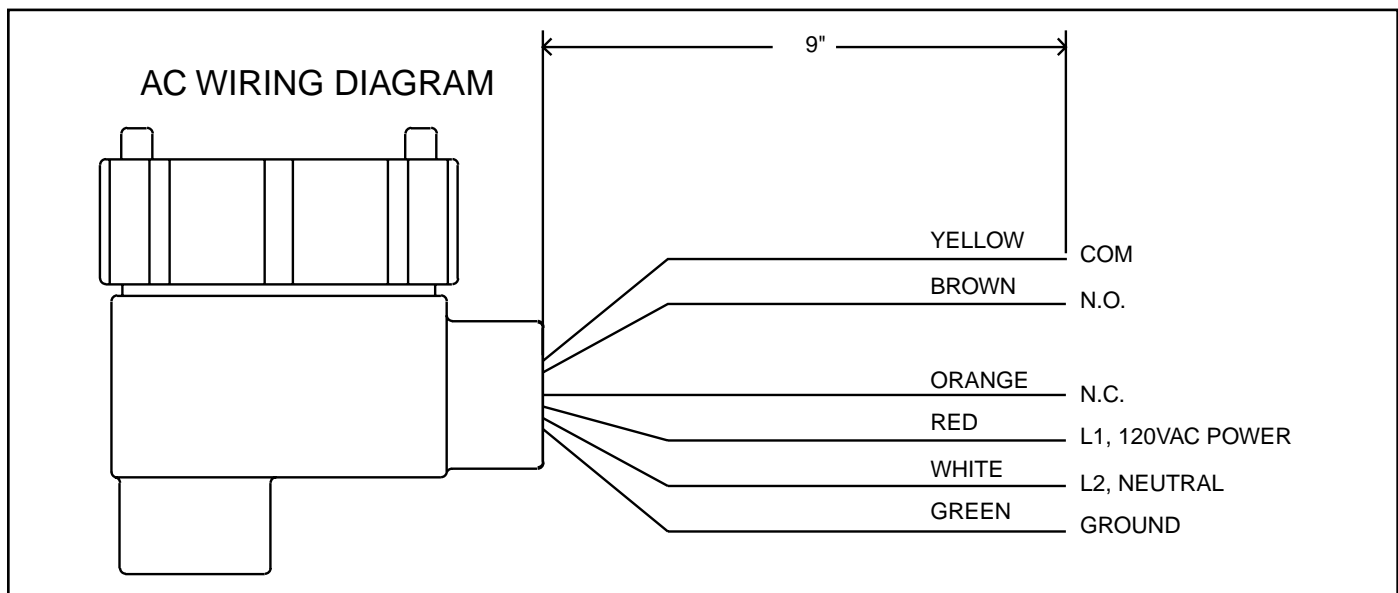

Figure 3

WARNING

To avoid electrical shock disconnect all sources of power before wiring.

5.2 Relay Connections

- 5.2.1 Set point relay has a SPDT relay contact.

- 5.2.2 Make relay connections.
(see figure 3, page 5).

WARNING

Remove power source before moving jumpers 120 VAC is present.

DANGER

SECTION 3 - CALIBRATION

6.0 Speed Range/ Hysterisis Selection

- 6.1 The operating speed range of the A1500 Series is 10 RPM - 4000 RPM.
- 6.2 Remove back cover of the motion switch.
- 6.3 Configure the two jumper pins for the maximum operating speed according to the speed range chart.
(see figure 4, page 6).
- 6.4 Configure the hysteresis jumper pin according to the set point chart.

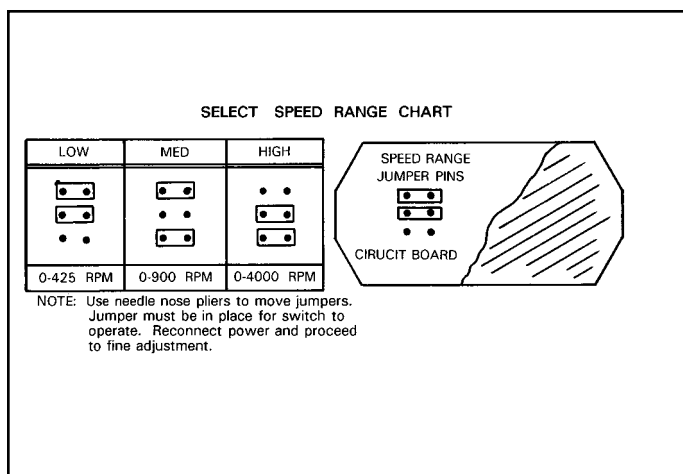

Figure 4

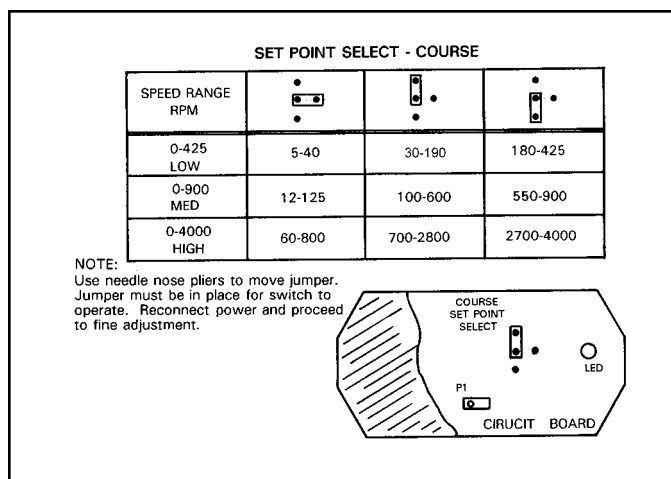

Figure 5

7.0 Set Point Calibration

7.1 The A1500 Series speed switch is calibrated while the monitored machine is running and power is applied to the speed switch. The relay will be energized while the operating speed is above the calibrated set point and de-energized while the operating speed is below the calibrated set point. The relay status is indicated by the red LED on the A1500 Series circuit board.

(LED on = Relay energized and operating speed is above calibrated set point)

(LED off = Relay de-energized and operating speed is below calibrated set point)

7.2 Start calibration by applying power to the A1500 Series speed switch and running the machine at normal operating speed. If the red LED is on this indicates that the operating speed is above the calibrated set point. To adjust the set point turn potentiometer P1 CCW until the red LED turns off. Then turn potentiometer P1 CW slowly until the red LED comes on and continue turning for the preferred set point (1/8 turn = approximately a 20% under speed set point). For under speed indication applications the red LED will be on during normal operation.

7.3 If the red LED is off this indicates that the operating speed is below the calibrated set point. To adjust the set point turn potentiometer P1 CW until the red LED turns on. Then continue turning potentiometer P1 CW slowly for the preferred set point (1/8 turn = approximately a 20% under speed set point). For under speed applications the red LED will be on during normal operation.

7.4 Confirm set point operation by slowing or stopping the machine.

WARNING

Do not set the relay trip point below 10 RPM. Setting the trip point below 10 RPM can result in the relay remaining energized even if the monitored shaft is rotating slower than 10 RPM. Operate the monitored machine and check the set point function before placing the switch in service.

A1500GEC WIRING DIAGRAM

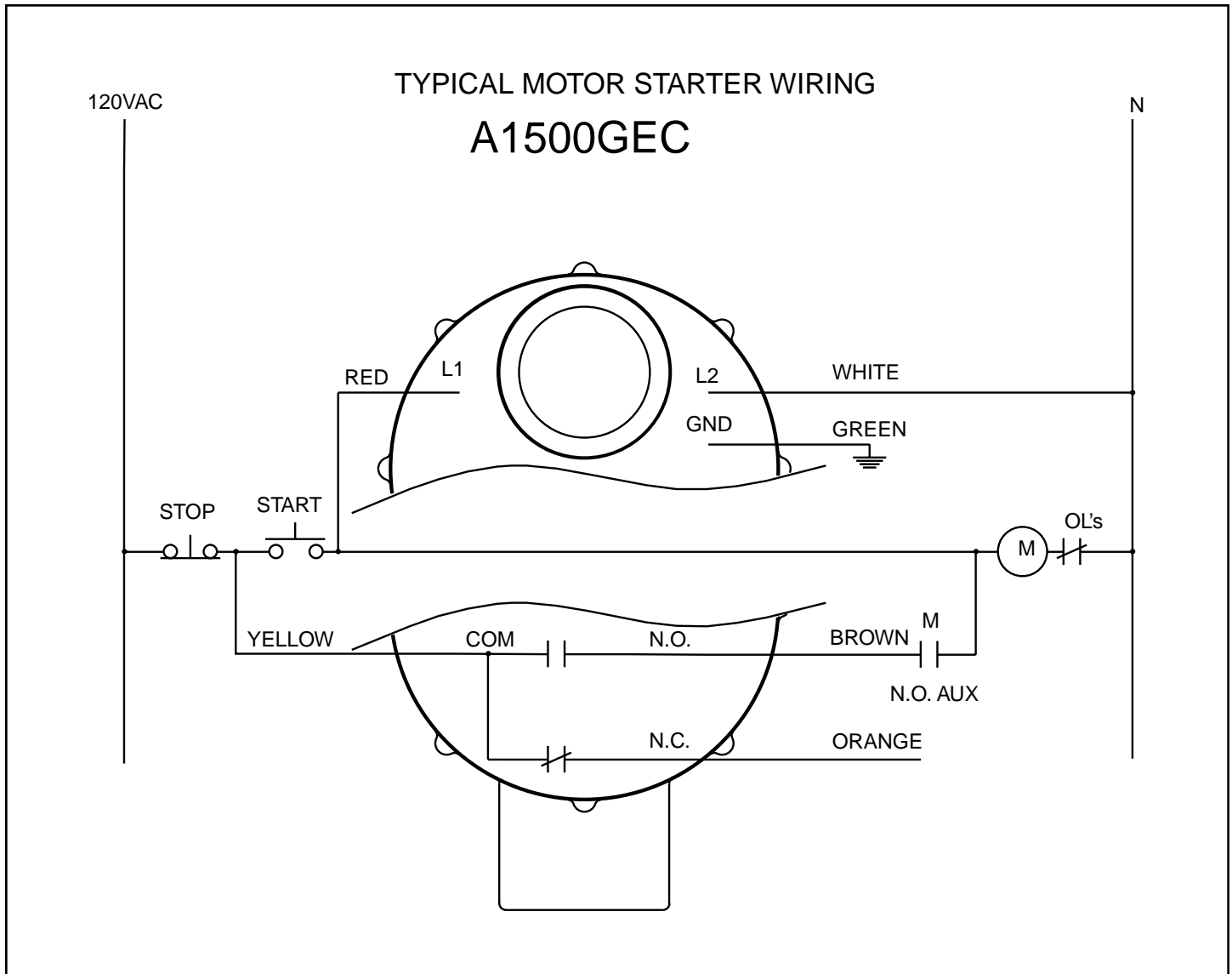

Figure 6

When the start pushbutton is pressed the A1500GEC speed switch is powered on and a “power on” delay of approximately 7 seconds begins. During the “power on” delay the relay contacts are held in the switched position allowing the motor to bring the machine to operating speed. As long as the monitored shaft is above the set point speed before the “power on” delay period has expired, the relay contacts will remain in the switched position allowing the monitored machine to run normally. If the monitored shaft speed stops or slows down below the set point speed the N.O. relay contact holding in the motor starter contact will open and drop out the motor starter. The “power on” delay is reset when the motor starter drops out and does not restart until the start pushbutton is pressed.

An additional contact is available to sound an alarm horn or turn on another type of warning device.

SPARE PARTS LIST

Part No.	Description
1729GEC	A1500GEC Switch without disc and bracket
1217	Mounting Bracket
1136	4" Magnet disc
1378	8" Magnet disc

LIMITED WARRANTY

Process Control Systems, Inc. will repair or replace, at their option, F.O.B. factory, any part or unit which proves to be defective in material or workmanship within five years of purchase date, provided that part of the unit was installed and operated as recommended, to be established by examination of the part or unit at the factory. Goods returned under warranty must be shipped prepaid to the factory and accompanied by the serial number, description of defect, order number and date of purchase.

This warranty shall not apply to any Maxigard™ product which shall have been repaired or altered outside of the Process Control Systems factory or has been subject to misuse, negligence or accident.

Process Control Systems, Inc. warrants its products, but not their application, and shall not be liable for any incidental or consequential damages incurred through the use or loss of use of a Process Control Systems product. No representatives or other person is authorized or permitted to make any warranty or assume for this company any liability not strictly in accordance with this guarantee.

There is no further warranty either expressed or implied beyond that set forth herein.