



PROCESS CONTROL SYSTEMS, INC.

327 LAKE HAZELTINE DRIVE, CHASKA, MN 55318

952-361-3026

(Fax) 952-368-4219

800-328-0738

MAXIGARD™



A4000 and A4000NF ROTATION DETECTOR

Introduction

The MAXIGARD A4000 and A4000NF are fail safe devices designed to monitor the rotational direction of a critical shaft. They are precision built of quality material and factory tested to insure long life and trouble free operation.

Principle of Operation

When the monitored shaft (with the magnet disc or optional magnet wrap attached) is rotating, magnets mounted in the disc or wrap pass in front of the sensing head, generating a signal. This signal is not impaired by build-up dust or any other foreign material on the magnet disc or sensing head. The signal is processed through an electronic circuit and energizes a relay. The relay has (2) SPST contacts (NO/NC). These contacts can be used to control, indicate, or alarm. The A4000 is so designed that when the rotation of the monitored shaft changes from the pre-selected rotation mode, the switch relay will de-energize causing an alarm condition.

The design of the A4000 is to provide a warning when there is a reversal of standard shaft rotation, commonly called windmilling.

Components

THE A4000 and A4000NF ROTATION DETECTOR INCLUDES:

- MAGNET DISC
- MOUNTING BRACKET
- CIRCUITRY
- ENCLOSURE

CALL TOLL FREE  800-328-0738

www.maxigard.com

E-mail: techsupport@maxigard.com

SECTION 1 - MECHANICAL

1.0 Magnet Disc

- 1.1 The end of the shaft to be monitored should be square to prevent excessive disc wobble.
- 1.2 Center drill and tap the shaft end. (Suggested #21 drill and #10-32NF tap). Bolt the magnet disc to the end of the shaft. Use “Loc-tite” to keep the bolt and disc tight on the shaft.
(see figure 1, page 3).

2.0 Magnet Wrap (optional)

- 2.1 Separate the two halves of the magnet wrap by loosening the cap screws holding the two halves together.
- 2.2 Place both halves of the magnet wrap around the shaft. Re-insert and tighten the cap screws making sure the wrap is square to the shaft.
(see figure 2, page 3).

NOTE

There will be a slight gap between the two halves after tightening. This gap will not affect the generated signal.

3.0 Mounting the Sensor

NOTE

For purpose of instruction, C.W. rotation is considered to be with the direction of the sensor indicating arrow.

- 3.1 Place the sensor so that it's centered directly in front of the magnets in the magnet disc or optional magnet wrap
(see figure 1 & 2, page 3).
- 3.1.1 The gap setting between the sensor and magnet disc or optional magnet wrap should be approximately 1/2”.

3.2 Magnet Disc

- 3.2.1 The arrow on the face of the sensor must be perpendicular to the rotational travel of the magnet disc.
(see figure 1 & 2, page 3)

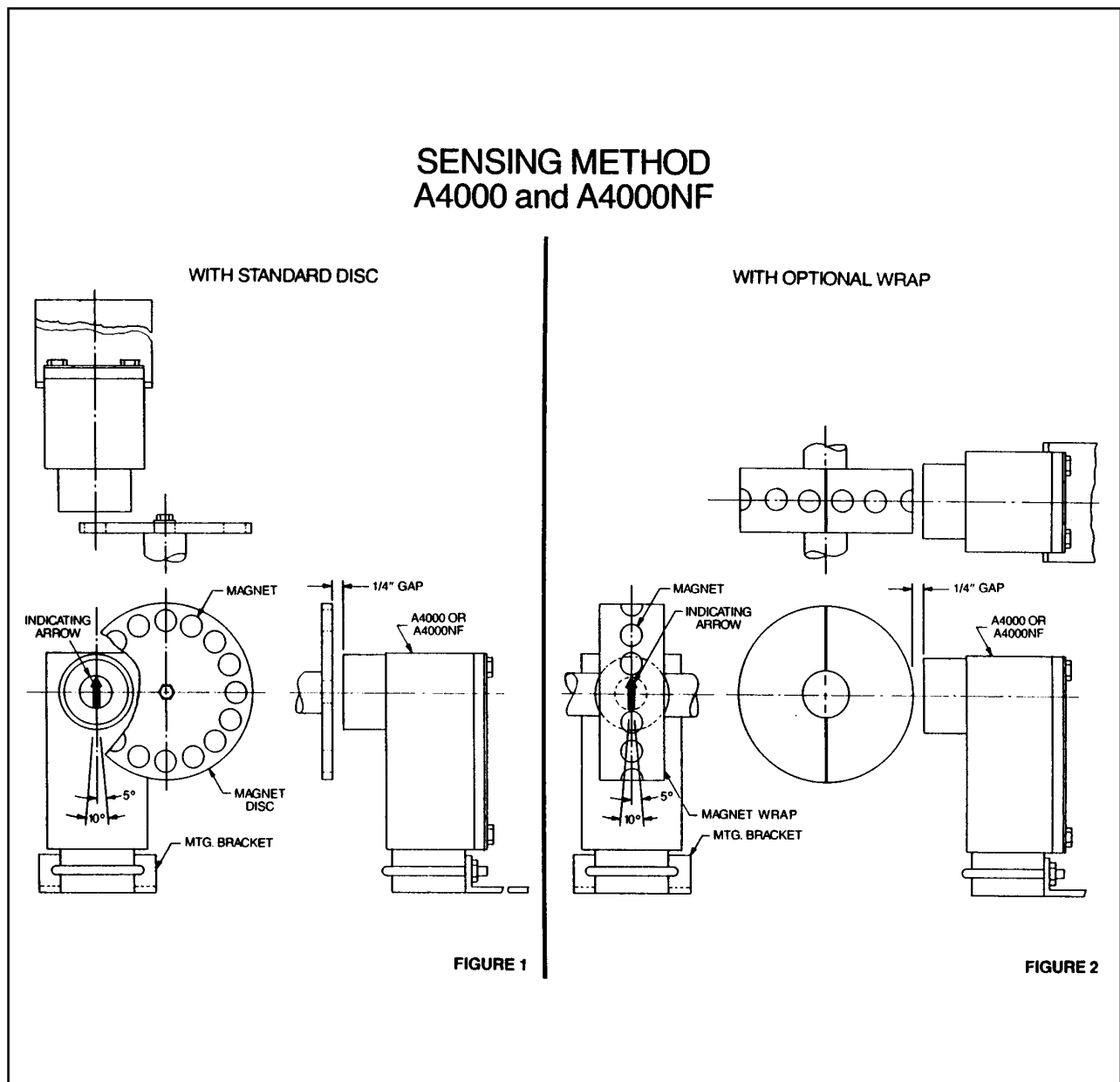

3.3 Magnet Wrap (optional)

- 3.3.1 The arrow on the face of the sensor must be perpendicular to the monitored shaft.
(see figure 2, page 3)
- 3.3.2 If the indicating arrow is pointing in the direction of the shaft rotation, sensing head set up is complete.

3.3.3 If the shaft rotation is counter to the indicating arrow, change the directional selector pins.
(see figure 5, page 7)

3.4 Green LED Indicating Light

3.4.1 Locate the Green LED light on the main circuit board. This LED is used to indicate that the A4000 circuit is receiving pulses from the sensing head.
(see figure 5, page 7 and figure 7, page 9)

3.4.2 Once the magnet disc or magnet wrap and sensor have been installed and wired, apply power 115 VAC to the A4000 switch and run the monitored machine.

3.4.3 The Green LED light should be on the flashing, if not, check the sensor alignment gap setting, and the sensor wiring. The flashing LED indicates the A4000 circuit is receiving pulses.

4.0 Sensor Enclosure

4.1 A4000, is UL/CSA listed and rated, Class 1, GR. D, Class 2, E, F, & G. This is not waterproof.
(see figure 3A, page 5)

4.2 A4000NF is rated NEMA 3, PVC.
(see figure 3B, page 5)

5.0 Wiring and Energizing

5.1 Connect 115 VAC to Red and White wires.
(see figure 4A & 4B, page 6)

CAUTION

Disconnect 115 VAC power source before making wire connections to the Red and White wires. Failure to do so, could result in electrical shock and injury.

Model A4000

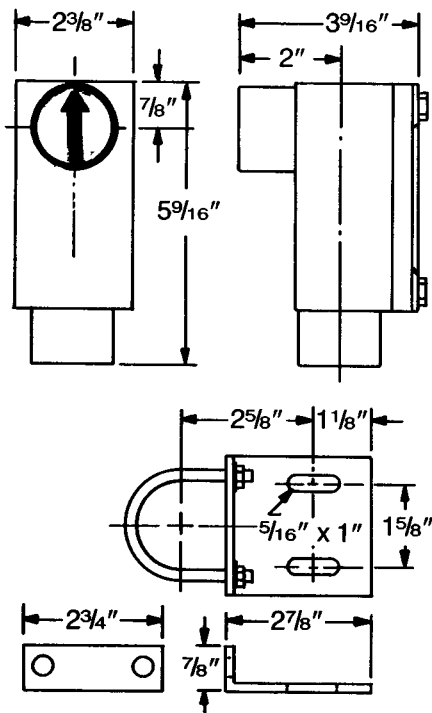

FIGURE 3A

Model A4000NF

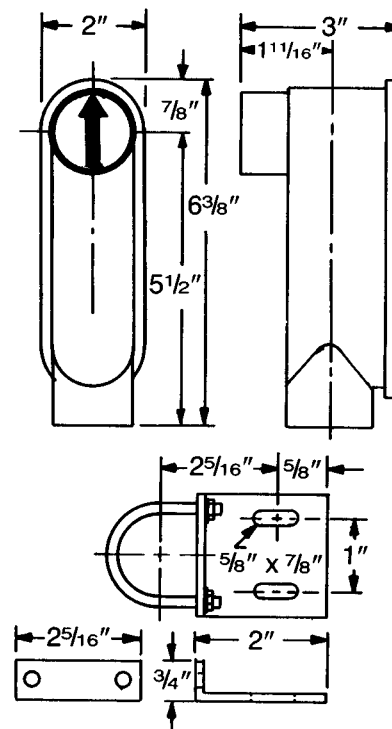
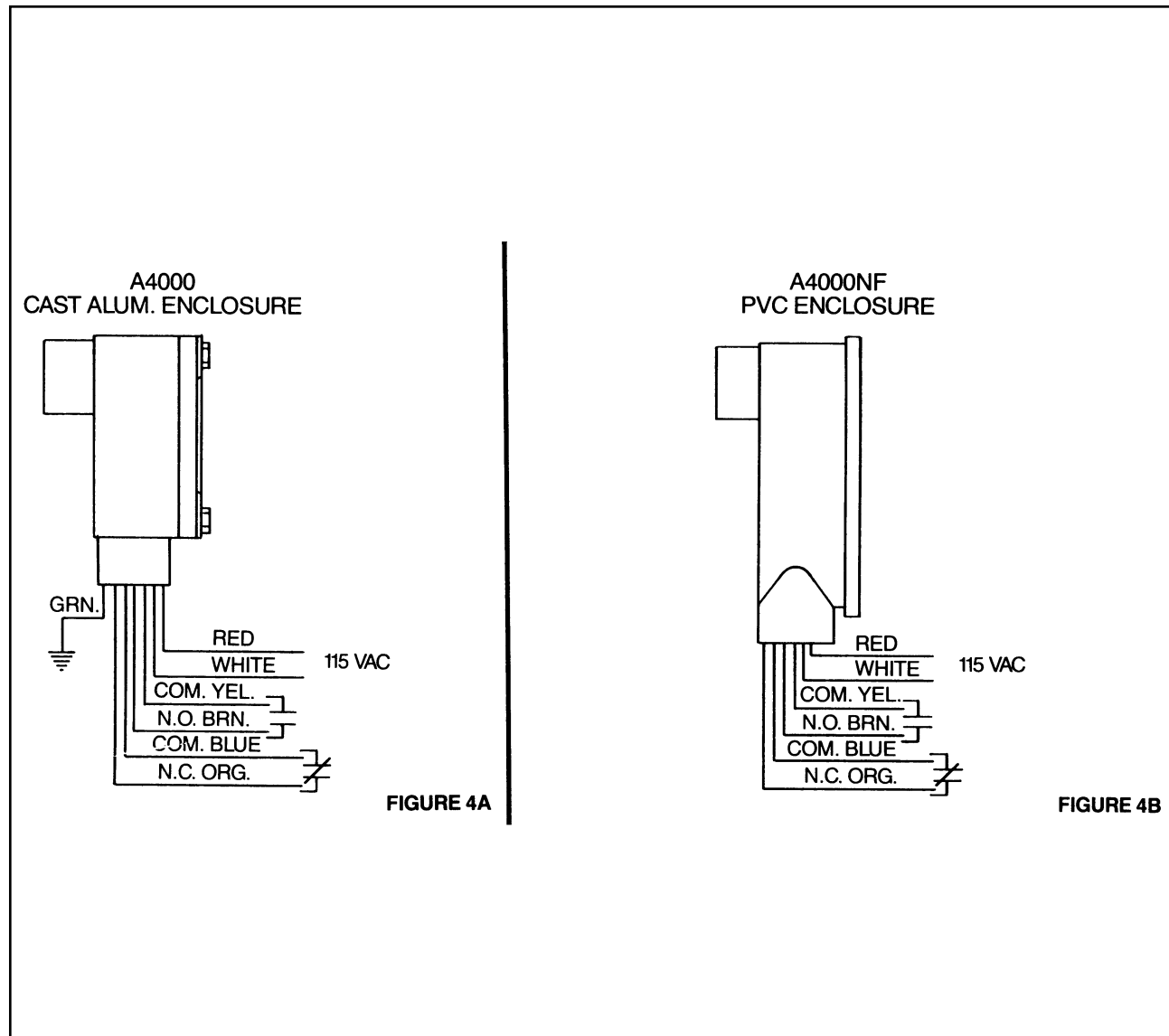

FIGURE 3B

- 5.2 Make relay connections as shown.
(see figure 4A & 4B, page 6)

CAUTION

Check wiring connections before applying power, switch can be damaged by improper wiring.



6.0 Rotation Direction Selection

NOTE

If "Bi-directional Relay" option is in place - proceed to Section 7.0, if not, proceed as follows.
(see figure 6 & 7, page 9)

6.1 Rotation Selector Pins

- 6.1.1 The rotation selection pins have been factory set for C.W. rotation as normal.
(see figure 5, page 7)
- 6.1.2 To change to a C.C.W. rotation mode, re-position the selector pins jumpers as shown in the detail. Use a needle nose plier to gently pull up on the jumper and re-position.
(see figure 5, page 7)

6.2 Relay Output Wiring

- 6.2.1 The (N.O.) contact will be held closed during correct selected rotation.
- 6.2.2 The (N.C.) contact will be held open during correct selected rotation.
- 6.2.3 The common wires (Yellow & Blue) can be wired together to create a Form C set of contacts. The contacts are rated 5 amps @ 120 VAC.

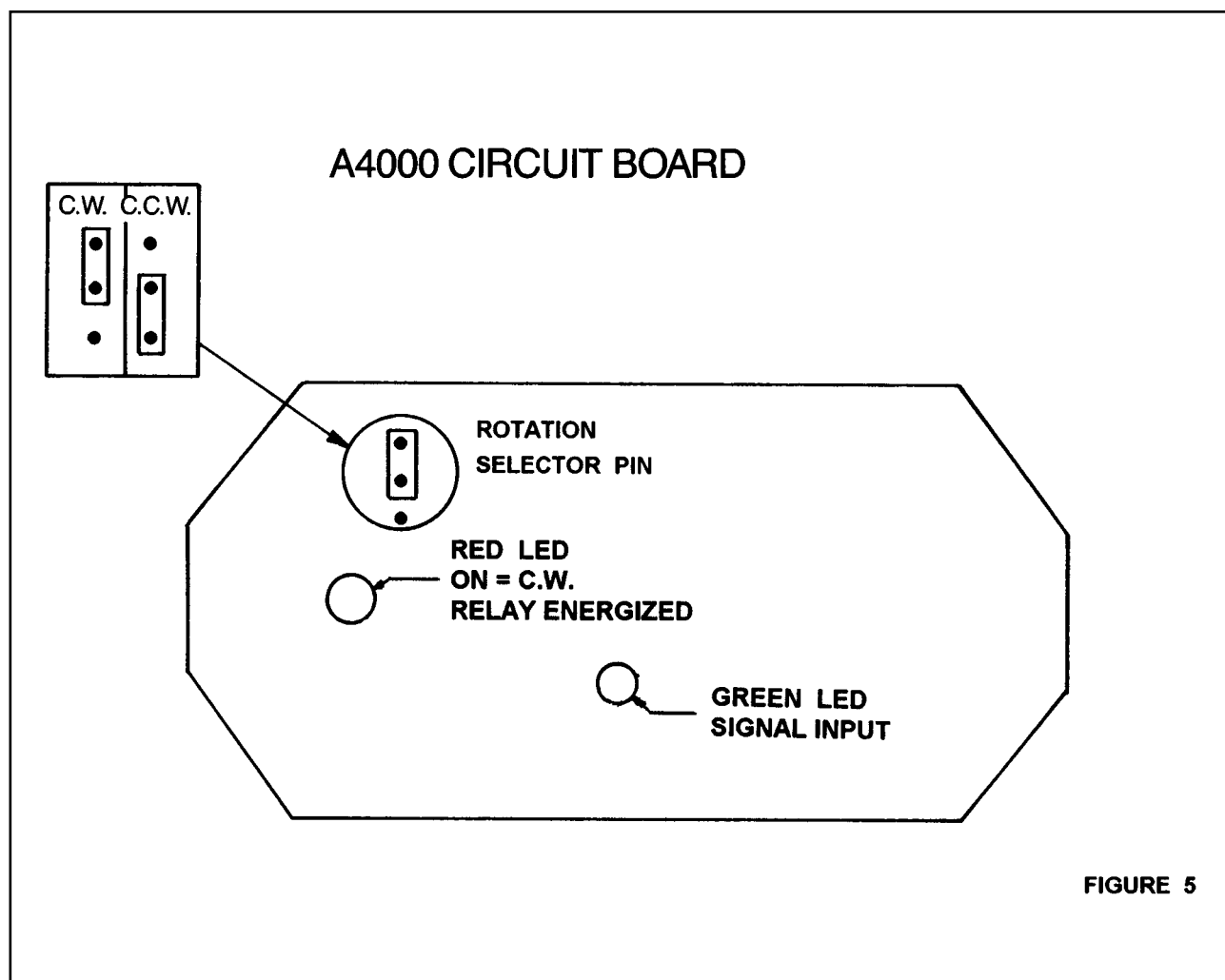

6.3 Sequence of Operation

NOTE

Assuming the selector pin jumper is set for C.W. rotation, the following will occur under normal operating conditions.

6.3.1 The relay will be energized during normal C.W. rotation.

6.3.2 The relay will de-energize if and when the shaft stops rotating.

6.3.3 When the shaft stops rotating and comes to a complete stop, there will be a (5) second delay before the relay de-energizes.

6.3.4 The relay will remain de-energized should the shaft start windmilling or turning in a C.C.W. direction.

6.3.5 The converse of 6.3.1 and 6.3.2 will happen if the selector pin jumper is set for C.C.W. rotation.

7.0 Bi-directional Dual Relay Outputs (optional)

Relays are SPST - 5 amp @ 120 VAC.

7.1 Relay (No. 1) Operating Status (located on the main circuit board)

7.1.1 Relay is (N.C.) when shaft is rotating C.W., Red LED light is on, located on the main circuit board.
(see figure 7, page 9)

7.1.2 Relay is (N.O.) when shaft is at zero speed, or rotating C.C.W., Red light is off, located on the main circuit board.
(see figure 7, page 9)

7.2 Relay (No. 2) Operating Status (located on auxiliary circuit board)

- 7.2.1** Relay is (N.C.) when shaft is rotating C.C.W., Amber LED light is on, located on the auxiliary circuit board.
(see figure 7, page 9)
- 7.2.2** Relay is (N.O.) when shaft is rotating C.W., Amber LED is off, located on the auxiliary circuit board.
(see figure 7, page 9)
- 7.2.3** Both relays will be (N.O.) when the monitored shaft is at zero speed.
- 7.2.4** There will be a (5) second delay of the relay mode change when the monitored shaft comes to zero speed.

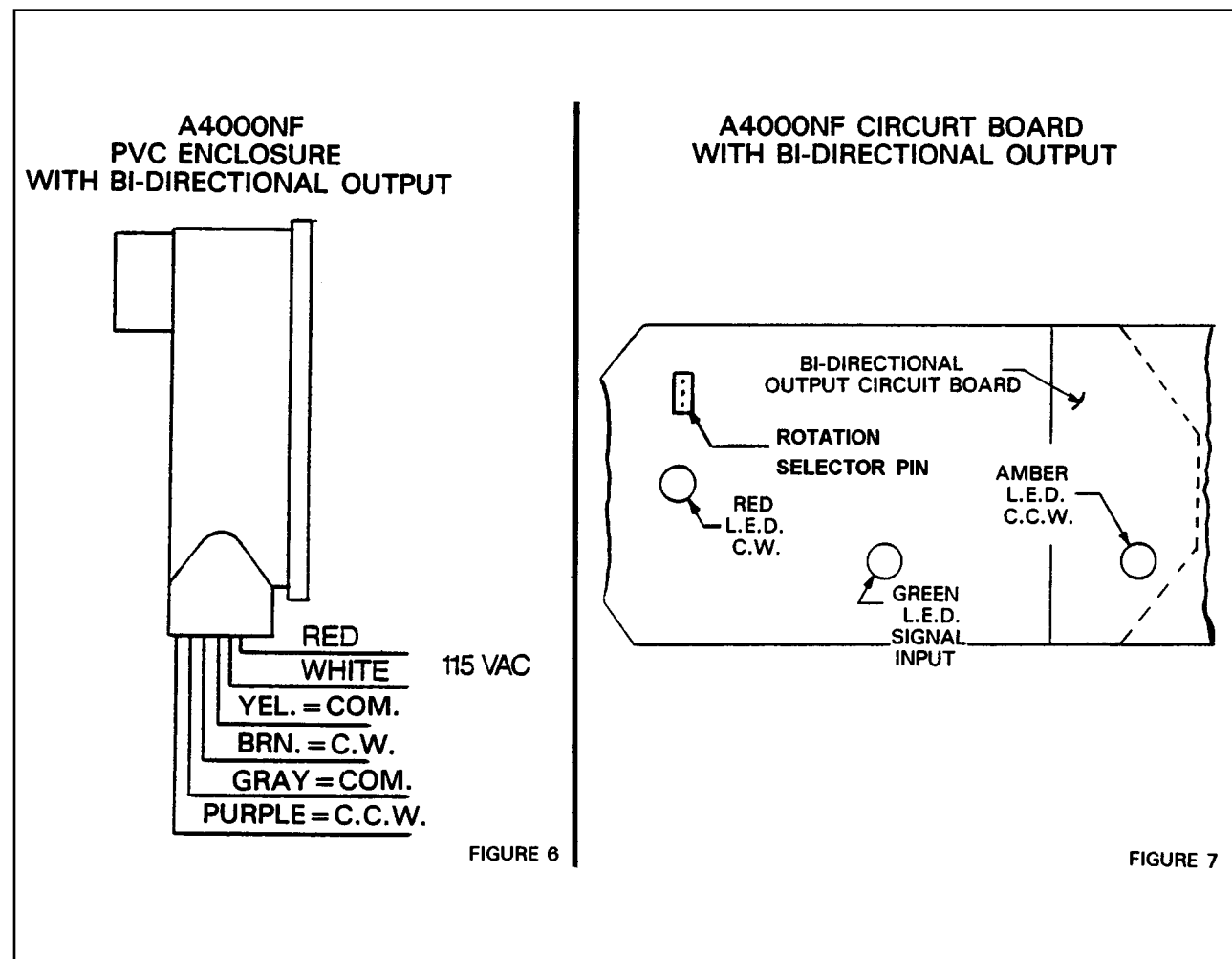

SPARE PARTS LIST

Part No.	Description
1217	Mounting Bracket A4000
1234	Mounting Bracket A4000NF
1480	Magnet Disc 8"
1464	A4000 W/O Disc or Bracket
1465	A4000NF W/O Disc or Bracket
1487	A4000NF W/Bi-direction OP

LIMITED WARRANTY

Process Control Systems, Inc. will repair or replace, at their option, F.O.B. factory, any part or unit which proves to be defective in material or workmanship within five years of purchase date, provided that part of the unit was installed and operated as recommended, to be established by examination of the part or unit at the factory. Goods returned under warranty must be shipped prepaid to the factory and accompanied by the serial number, description of defect, order number and date of purchase.

This warranty shall not apply to any Maxigard™ product which shall have been repaired or altered outside of the Process Control Systems factory or has been subject to misuse, negligence or accident.

Process Control Systems, Inc. warrants its products, but not their application, and shall not be liable for any incidental or consequential damages incurred through the use or loss of use of a Process Control Systems product. No representatives or other person is authorized or permitted to make any warranty or assume for this company any liability not strictly in accordance with this guarantee.

There is no further warranty either expressed or implied beyond that set forth herein.