



PROCESS CONTROL SYSTEMS, INC.
 327 LAKE HAZELTINE DRIVE, CHASKA, MN 55318

952-361-3026
 (Fax) 952-368-4129
 800-328-0738

MAXIGARD™



MAXIGARD A2000 SPEED SWITCH

Introduction

The Maxigard A2000 Speed Switch is designed to monitor the rotation of critical driven shafts. The switch is precision built of quality material and completely factory tested to insure long life and trouble free operation.

Principle of Operation

The Maxigard A2000 speed switch is supplied with a non-contacting sensor and magnetic target. The sensor signal is not impaired by buildup of dust or any other foreign material on the magnet target or sensor. The A2000 has two adjustable set points and is designed to detect under speed and/or over speed of the monitored shaft. The low set point relay has a built in power up time delay of approximately 7 seconds which allows machinery controlled through the motor starter circuit to reach the set point during start-up. The delay activates on power-up only and can be disabled with a field selectable jumper pin configuration. When properly installed and calibrated, in the event of a power failure or loss of sensor signal the relays will de-energize and put the switch into an alarm condition.

Components

THE MAXIGARD A2000 SPEED SWITCH INCLUDES:

- 4" MAGNET DISC (OTHER OPTIONAL MAGNETIC TARGETS AVAILABLE)
- SENSOR WITH 10' OF CABLE AND MOUNTING BRACKET
- A2000 SPEED SWITCH CIRCUIT BOARDS WITH TWO 10 AMP RELAYS
- NEMA 4 ENCLOSURE

CALL TOLL FREE  800-328-0738

www.maxigard.com
 E-mail: techsupport@maxigard.com

SECTION 1 - MECHANICAL

1.0 Magnet Disc

- 1.1 The end of the shaft to be monitored should be square to prevent excessive disc wobble.
- 1.2 Center drill and tap the shaft end. (Suggested #21 drill and #10-32NF tap). Bolt the magnet disc to the end of the shaft. Use "Loc-tite" to keep the bolt and disc tight on the shaft.
(see figure 1A & 1C, page 3).

2.0 Magnet Wrap (optional)

- 2.1 Separate the two halves of the magnet wrap by loosening the cap screws holding the two halves together.
- 2.2 Place both halves of the magnet wrap around the shaft. Re-insert and tighten the cap screws making sure the wrap is square to the shaft.
(see figure 1B & 1D, page 3).

NOTE

There will be a slight gap between the two halves after tightening. This gap will not affect the generated signal.

3.0 Mounting the Sensor

- 3.1 Place the sensing head so it is centered directly in front of the magnets in the disc or optional wrap.
(see figure 1A & 1B, 1C & 1D page 3).
- 3.2 The gap setting between the sensor and magnet disc should be approximately 1/8" - 7/8".

SENSING METHOD

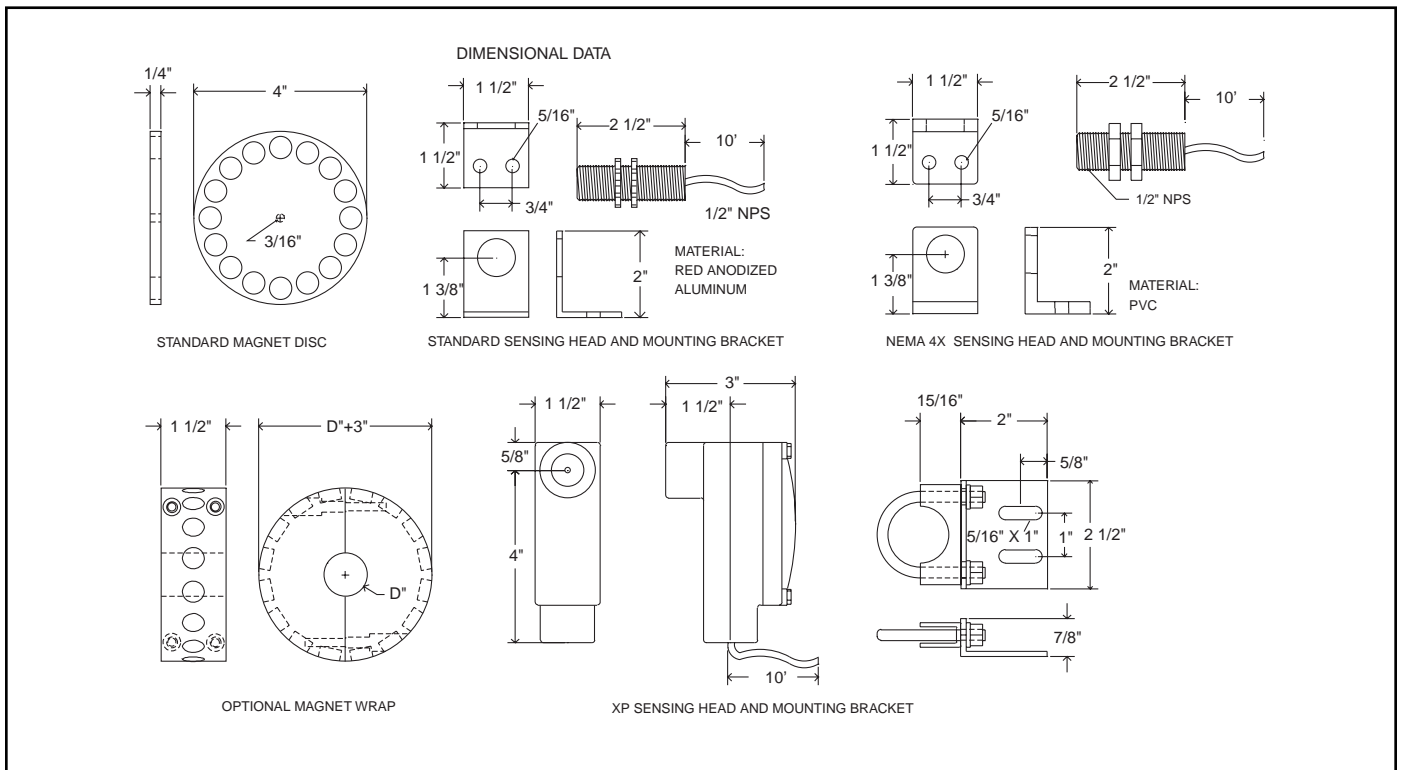
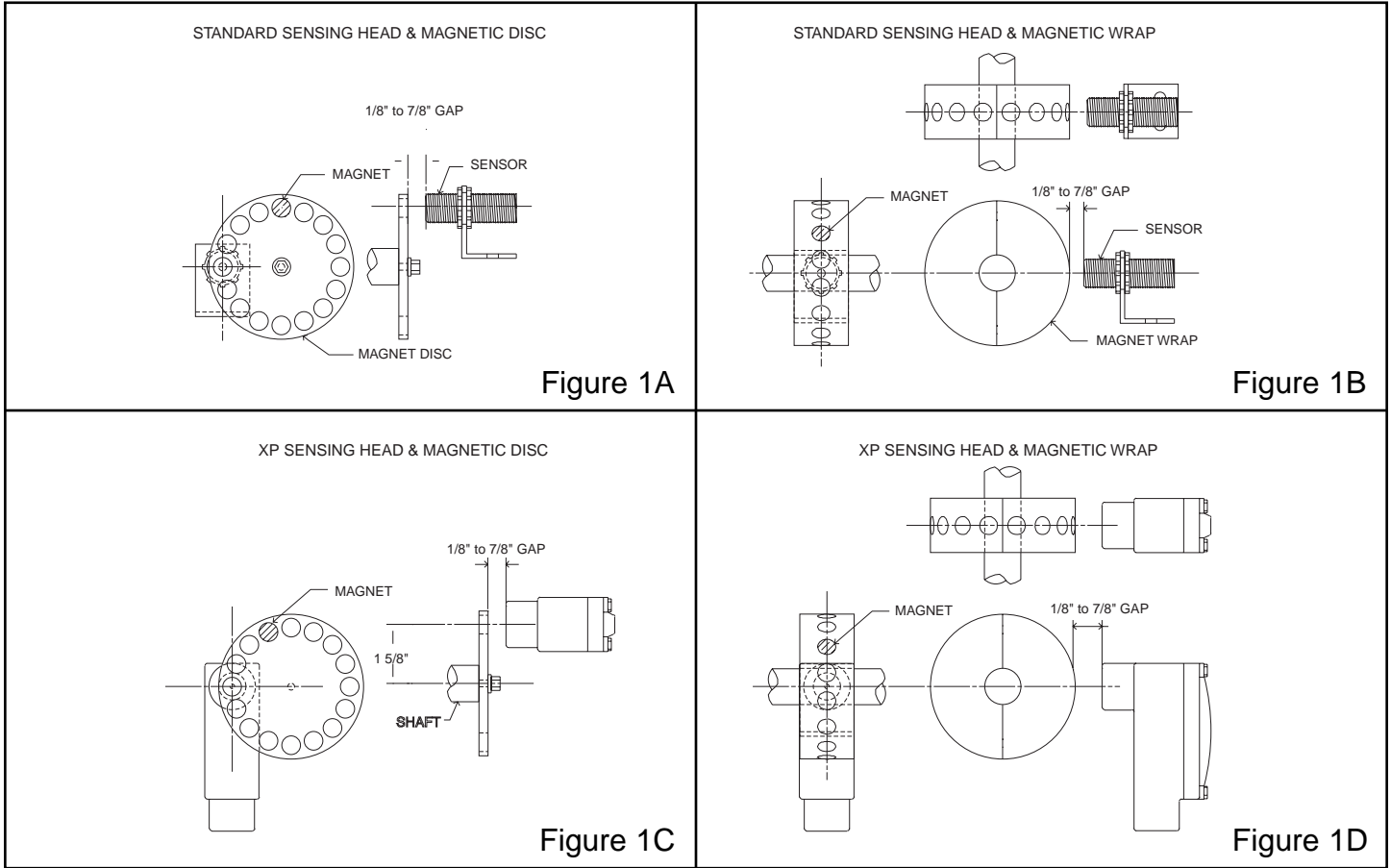

Figure 2

4.0 Speed Switch Enclosure

- 4.1 A2000 enclosures are UL listed/ CSA approved, rated NEMA 4, dust tight, oil tight and water tight painted carbon steel construction suitable for indoor and outdoor use. NEMA 4X fiberglass or stainless steel are available.
(see figure 3A & 3B, page 4)

CAUTION
Remove the circuit board from the enclosure before punching or drilling conduit holes. Be sure to remove all metal chips and filings.

NEMA 4 PAINTED CARBON STEEL

NEMA 4X FIBERGLASS

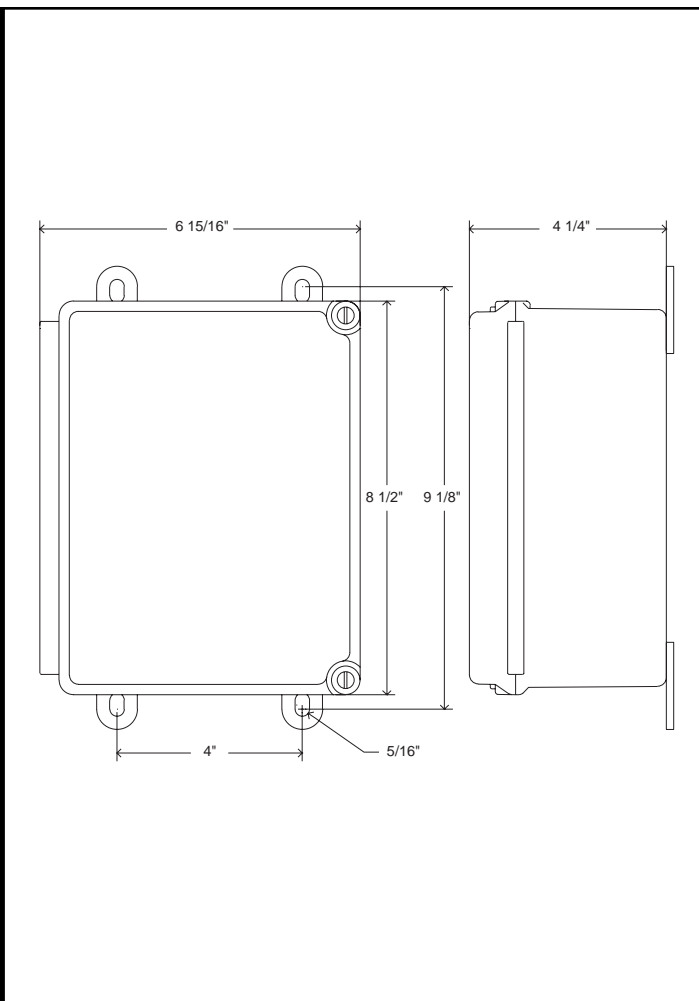
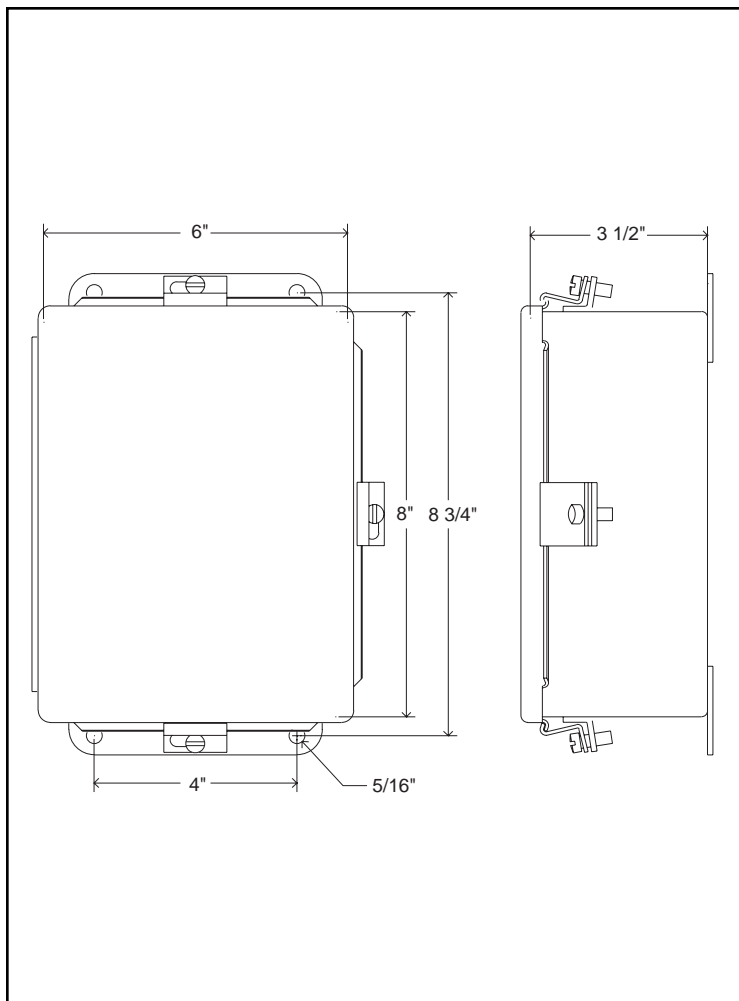

Figure 3A

Figure 3B

SECTION 2 - FIELD WIRING

5.0 Sensor Wiring

- 5.1** Connect the sensor cable to terminals black, white and shield located on terminal block TB1.
(see figure 4, page 6)
- 5.2** The sensor comes standard with 10' of cable. Additional cable can be added as required. Be sure to maintain continuity. Wrap the splice with the foil shield and electrical tape.

SENSING HEAD CABLE

Use "Belden" #8761 or equal. Cable should not be run in same conduit as power wires. Maximum distance of cable run 10,000 ft. Make good splice connections and check continuity.

6.0 Wiring the A2000 Speed Switch

WARNING

To avoid electrical shock disconnect all sources of power to the motor starter before wiring and observe voltage ratings of the speed switch.

- 6.1** Power connections and relay connections to the A2000 Speed Switch are shown on Figure 4, page 6. Also, figures 5, 6 and 7 show typical wiring diagrams.
- 6.2** Connect 120 VAC power to L1 and neutral to L2 on terminal block TB2 (see figure 4, page 6). See figures 5, 6 and 7 for examples of typical wiring diagrams. Connect equipment safety ground to GRD on terminal block TB2.
- 6.3** Make relay connections to terminal block TB2. Normally open contacts are held closed and normally closed contacts are held open when the operating speed exceeds the set point speed for that particular relay contact.
(see figure 4, page 6)

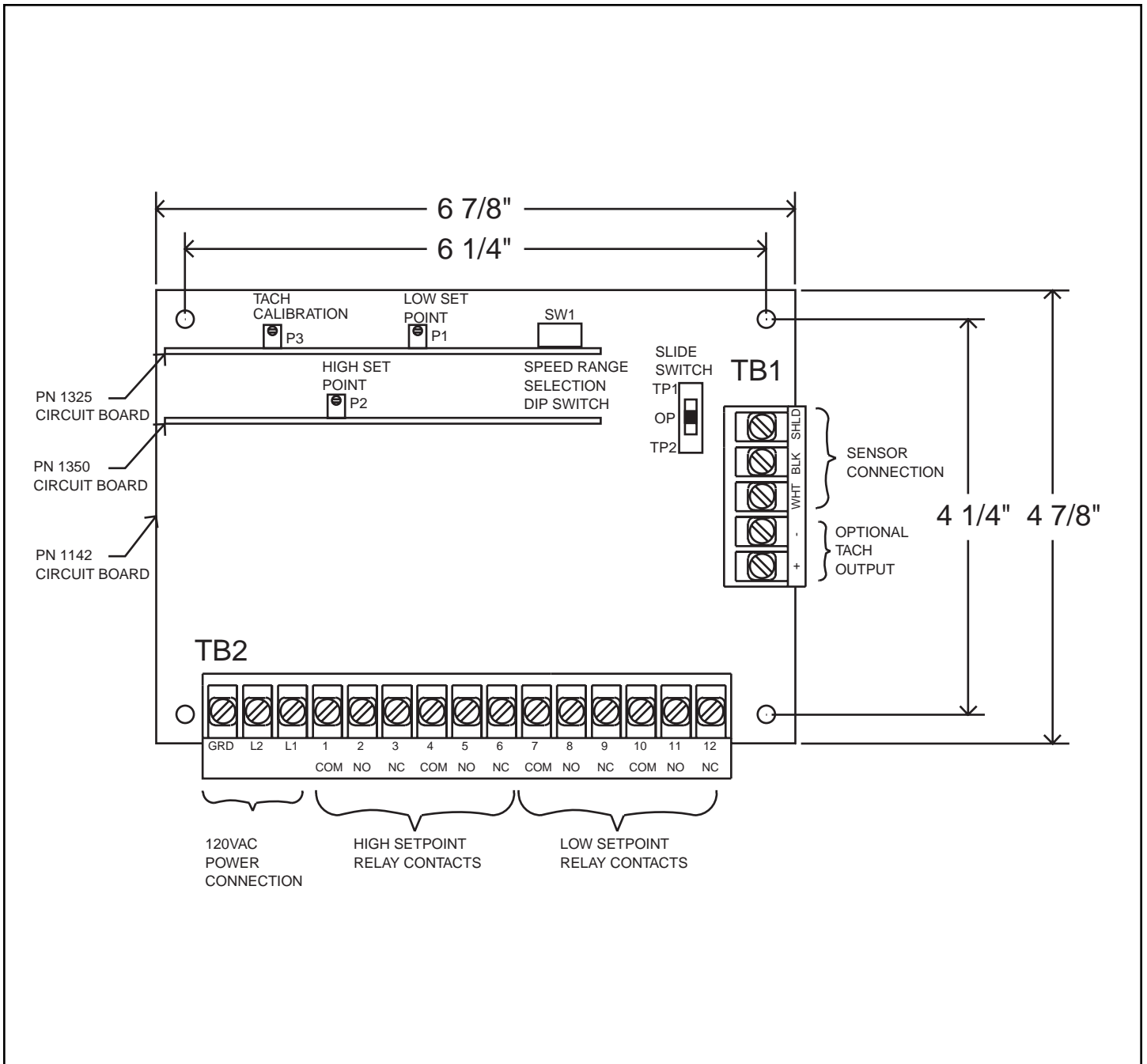

Figure 4

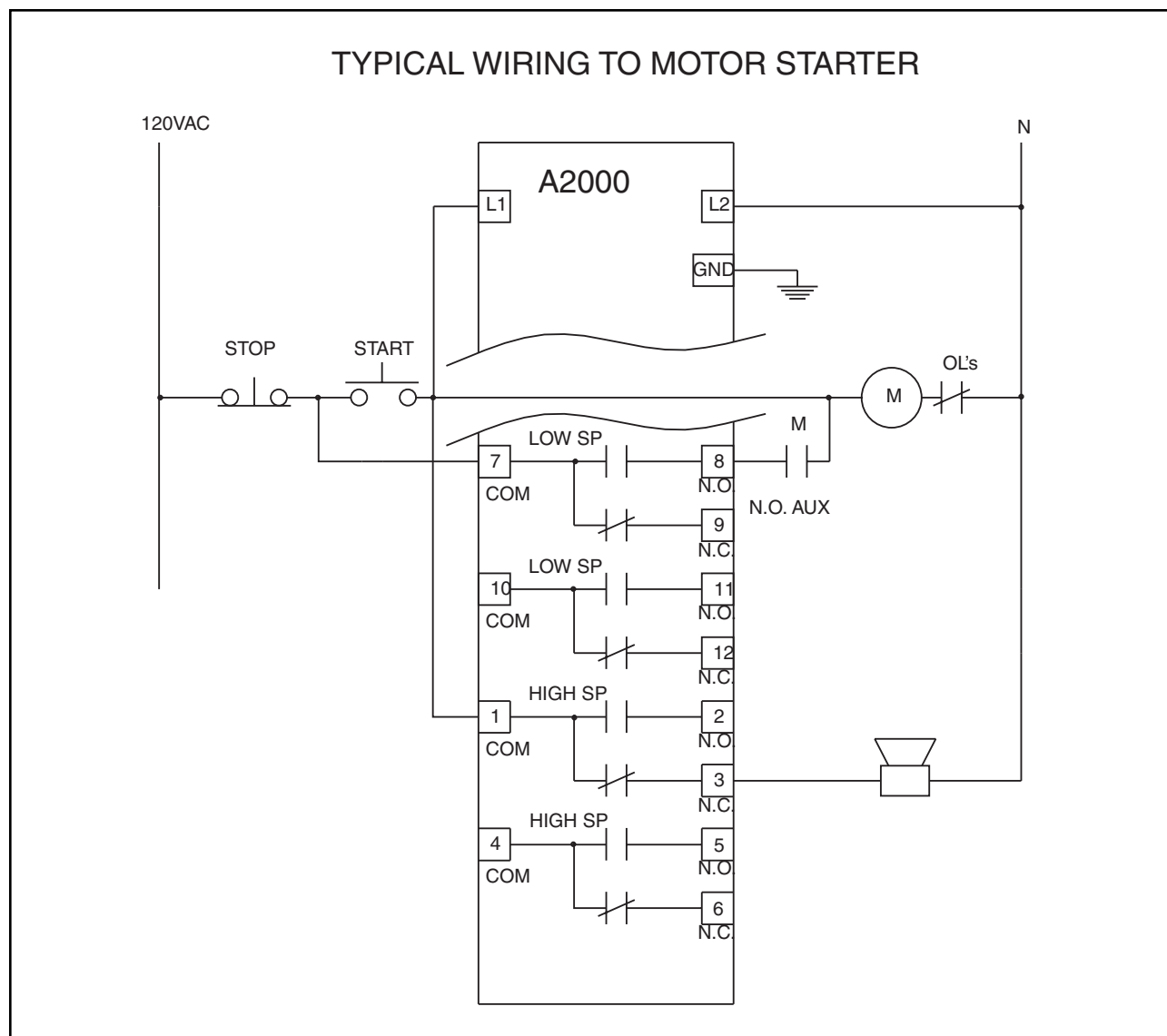

Figure 5

When the start pushbutton is pressed the A2000 speed switch is powered on and a “power on” delay of approximately 7 seconds begins. During the “power on” delay the low set point relay contacts are held in the switched position allowing the motor to run. As long as the monitored shaft speed is above the low set point speed before the “power on” delay period has expired, the relay contacts will remain in the switched position allowing the monitored machine to run normally. If the monitored shaft speed slows down or stops below the low set point speed the N.O. relay contact holding in the motor starter contact will open and drop out the motor starter. The “power on” delay is reset when the motor starter drops out and power is interrupted to the A2000.

The “power on” delay can be disabled by reconfiguring the time delay jumper pins. (see figure 8, page 10)

An additional set point is available to sound an alarm horn, turn on another type of warning device, or interlock with other equipment.

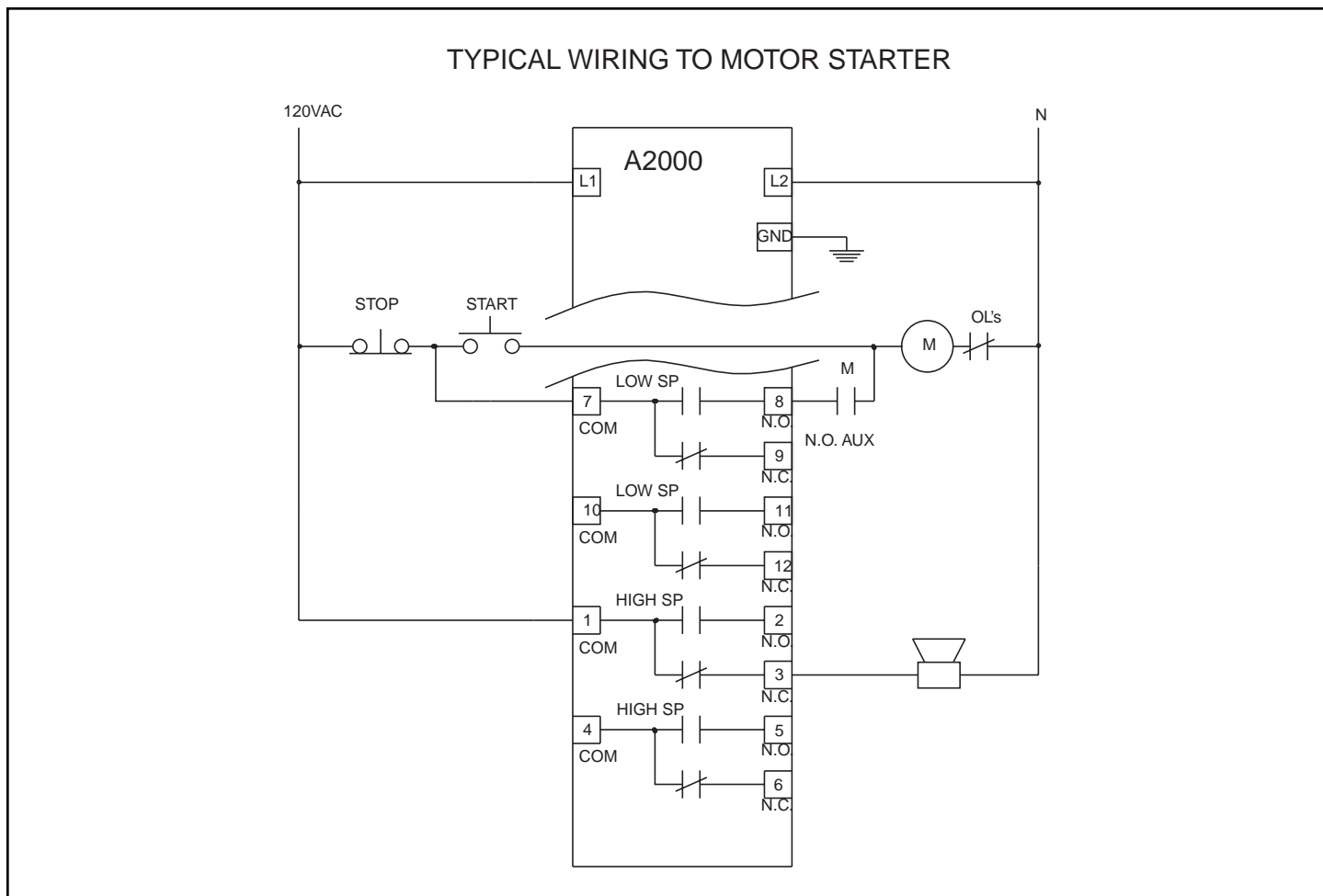

Figure 6

When 120 VAC is applied to L1 and L2 the A2000 speed switch is powered on and a “power on” delay of approximately 7 seconds begins. During the “power on” delay the low set point relay contacts are held in the switched position allowing the motor to run. As long as the monitored shaft speed is above the low set point speed before the “power on” delay period has expired, the relay contacts will remain in the switched position allowing the monitored machine to run normally. If the monitored shaft speed slows down or stops below the low set point speed the N.O. relay contact holding the motor starter contact will open and drop out the motor starter. The “power on” delay is reset when power is removed from L1 and L2.

If the A2000 is powered continuously the “power on” delay only occurs at initial power up and is not available for later restarts. If continuously powered the start pushbutton will need to be held closed until the monitored shaft reaches operating speed allowing the motor starter to seal through the motion switch contact.

The “power on” delay can be disabled by reconfiguring the time delay jumper pins. (see figure 8, page 10)

An additional set point is available to sound an alarm horn, turn on another type of warning device, or interlock with other equipment.

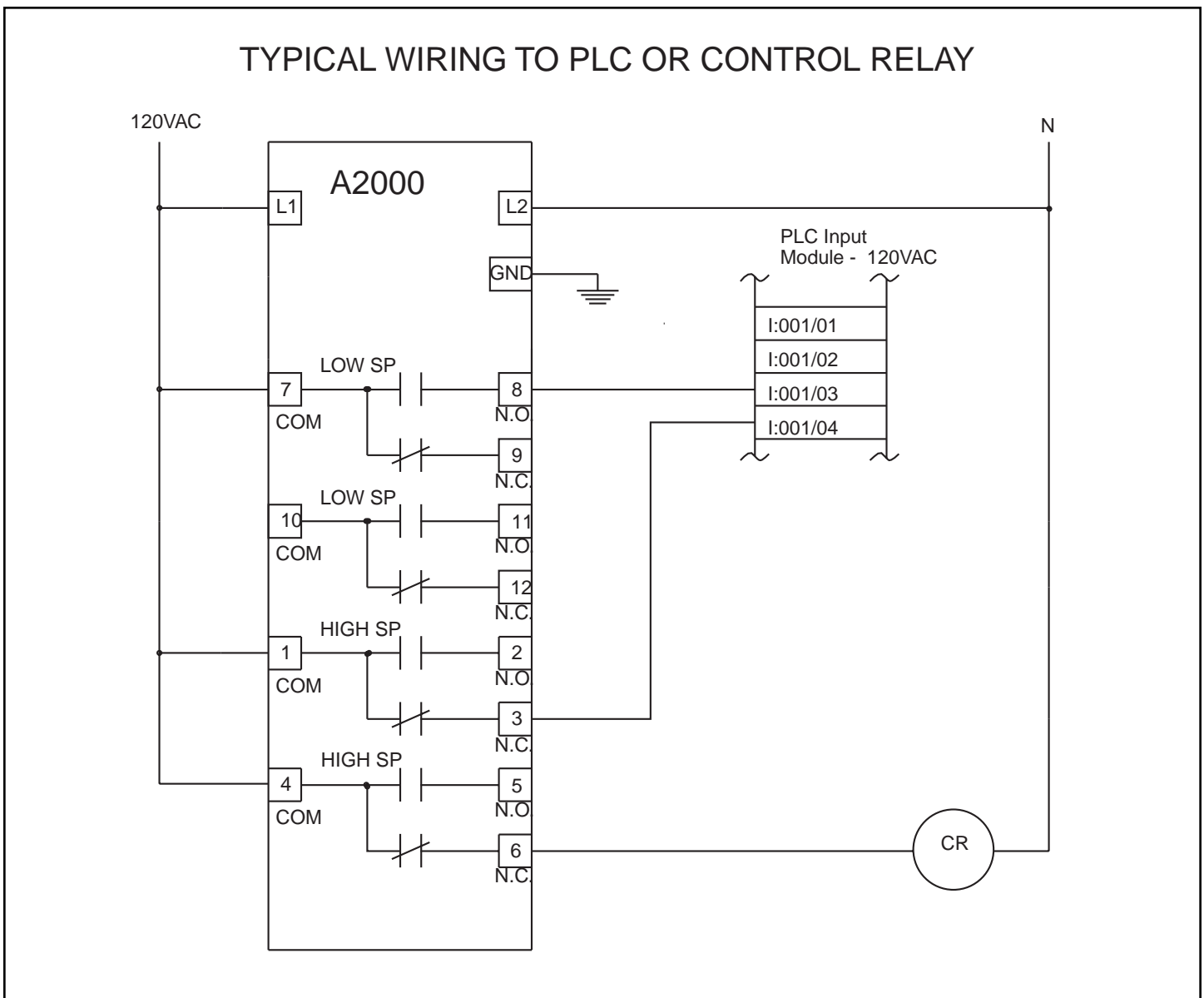

Figure 7

When 120 VAC is applied to L1 and L2 the A2000 speed switch is powered on and a "power on" delay of approximately 7 seconds begins. During the "power on" delay the low set point relay contacts are held in the switched position allowing the motor to run. As long as the monitored shaft is above the set point speed before the "power on" delay period has expired, the relay contacts will remain in the switched position. If the monitored shaft speed stops or slows down below the set point speed the N.O. relay contacts open. When the monitored shaft speed exceeds the set point the N.O. relay contacts close. The "power on" delay is reset when power is removed from L1 and L2. If the A2000 is continuously powered the "power on" delay only occurs at initial power up.

The "power on" delay can be disabled by reconfiguring the time delay jumper pins. (see figure 8, page 10)

SECTION 3 - CALIBRATION

7.0 A2000 Speed Switch Calibration

- 7.1** Set the A2000 dip switches for the proper speed range based on the normal operating speed of the monitored shaft. The dip switch is located on the low set point circuit board.
 (see figure 8, page 10)

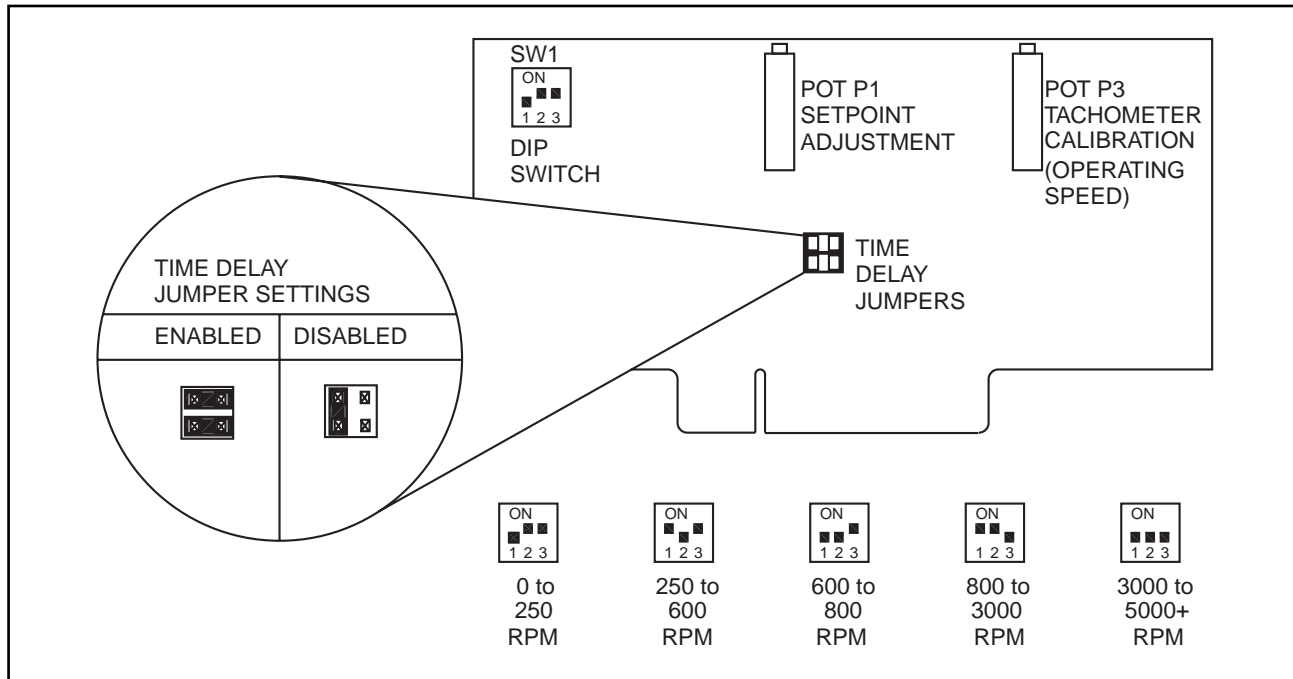

Figure 8

8.0 A2000 Start Delay Configuration

- 8.1** The A2000 can be configured with or without a 7 second start delay. With the start delay feature enabled the A2000 low set point relay will automatically energize for 7 seconds upon power-up. This feature is used to allow the monitored shaft to reach the set point speed during start up without causing an alarm condition. If the shaft has not reached the low set point speed before the 7 second start delay period has expired, then the A2000 switch will go into an alarm condition.

With the start delay feature disabled the A2000 relays will not energize until the monitored shaft speed exceeds the calibrated set point.
 (see figure 8, page 10)

9.0 Calibration with Voltmeter

If the optional tachometer is not supplied with the A2000, a voltmeter can be used to calibrate the speed switch. Connect the voltmeter leads to terminal block TB1 optional tach output connections (+) and (-).
(see figure 10, page 13)

- 9.1** To calibrate the operating speed place the slide switch in the operating speed position (OP). With the machine running at normal operating speed adjust potentiometer P3 (CCW to increase/CW to decrease) until the voltmeter reads the recommended DC voltage as shown on table 1.

OPERATING SPEED RPM	USE P3 TO ADJUST	USE P1/P2 TO ADJUST				
	RECOMMENDED 100% TACH OUTPUT VOLTAGE (OPERATION SPEED)	120% SETPOINT VOLTAGE	110% SETPOINT VOLTAGE	90% SETPOINT VOLTAGE	80% SETPOINT VOLTAGE	70% SETPOINT VOLTAGE
5-20	0.10	0.12	0.11	0.09	0.08	0.07
20-30	0.20	0.24	0.22	0.18	0.16	0.14
30-50	0.25	0.30	0.28	0.23	0.20	0.18
50-200	0.50	0.60	0.55	0.45	0.40	0.35
250+	1.00	1.20	1.10	0.90	0.80	0.70

Table 1

- 9.2 To calibrate the low set point place the slide switch in the low set point position (TP1). Calculate the desired set point value by taking a percentage of the operating speed tach output voltage from table 1.

EXAMPLE

If the operating speed of the monitored shaft is 300 RPM set P3 for a voltmeter reading of 1.00 VDC while the machine is running at 100%. For an 80% set point (240 RPM) set P1 for a voltmeter reading of .80 VDC. ($1.00 \text{ VDC} \times 80\% = .80 \text{ VDC}$) (see table 1)

Adjust potentiometer P1 until you reach the desired set point on the voltmeter (CW to increase/ CCW to decrease). The machine does not need to be running to make this adjustment.
(see figure 10, page 13)

- 9.3 To calibrate the high set point place the slide switch in the high set point position (TP2). Calculate the set point value by taking a percentage of the operating speed tach output voltage from table 1.

Adjust potentiometer P2 until you reach the desired set point on the voltmeter (CW to increase/ CCW to decrease). The machine does not need to be running to make this adjustment.
(see figure 9, page 12/ Figure 10 page 13)

- 9.4 Return the slide switch to the OP position. The meter will now display the operating voltage. The set points will still function properly if the slide switch is in the TP position.
(see figure 10, page 13)

- 9.5 A2000 speed switch is now calibrated.

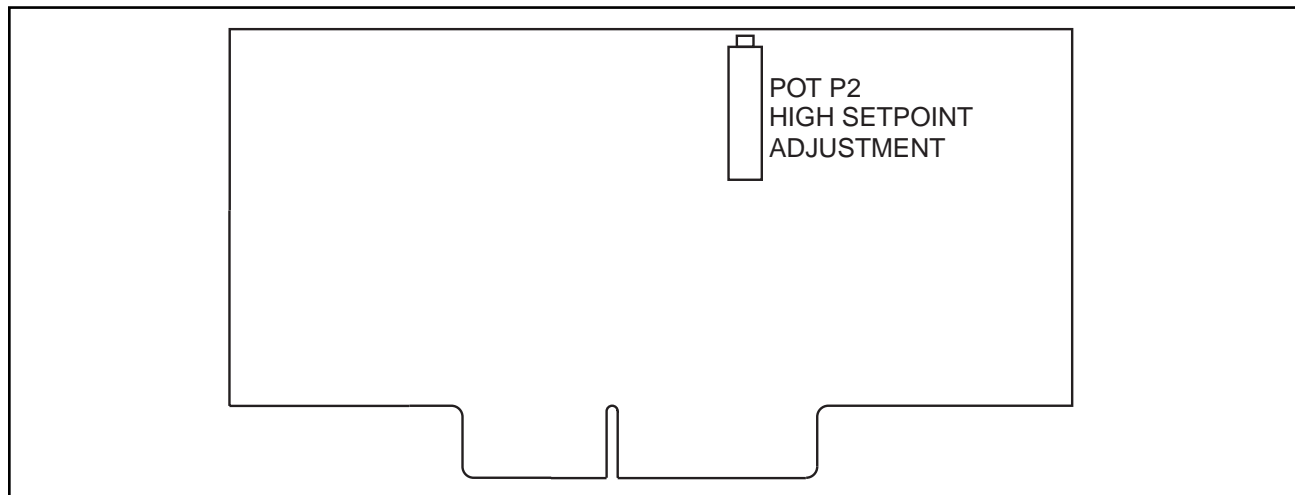

Figure 9

10.0 Calibration with Optional Tachometer

If the optional tachometer is supplied with the A2000 connect the meter as shown in figure 10, page 13.

- 10.1 To calibrate the operating speed place the slide switch in the operating speed position (OP). With the machine running at normal operating speed adjust potentiometer P3 until the display meter reads 100% (CCW to increase/ CW to decrease).
(see figure 10, page 13)
- 10.2 To calibrate the low set point place the slide switch in the low set point position (TP1). Adjust potentiometer P1 until you reach the desired set point on the display meter (CW to increase/CCW to decrease). The machine does not need to be running to make this adjustment.
(see figure 10, page 13)
- 10.3 To calibrate the high set point place the slide switch in the high set point position (TP2). Adjust potentiometer P2 until you reach the desired set point on the display meter (CW to increase/ CCW to decrease). The machine does not need to be running to make this adjustment.
(see figure 10, page 13)
- 10.4 Return the slide switch to the OP position. The meter will now display the operating speed. The set points will still function properly if the slide switch is in the TP position.
(see figure 10, page 13)
- 10.5 The A2000 speed switch is now calibrated.

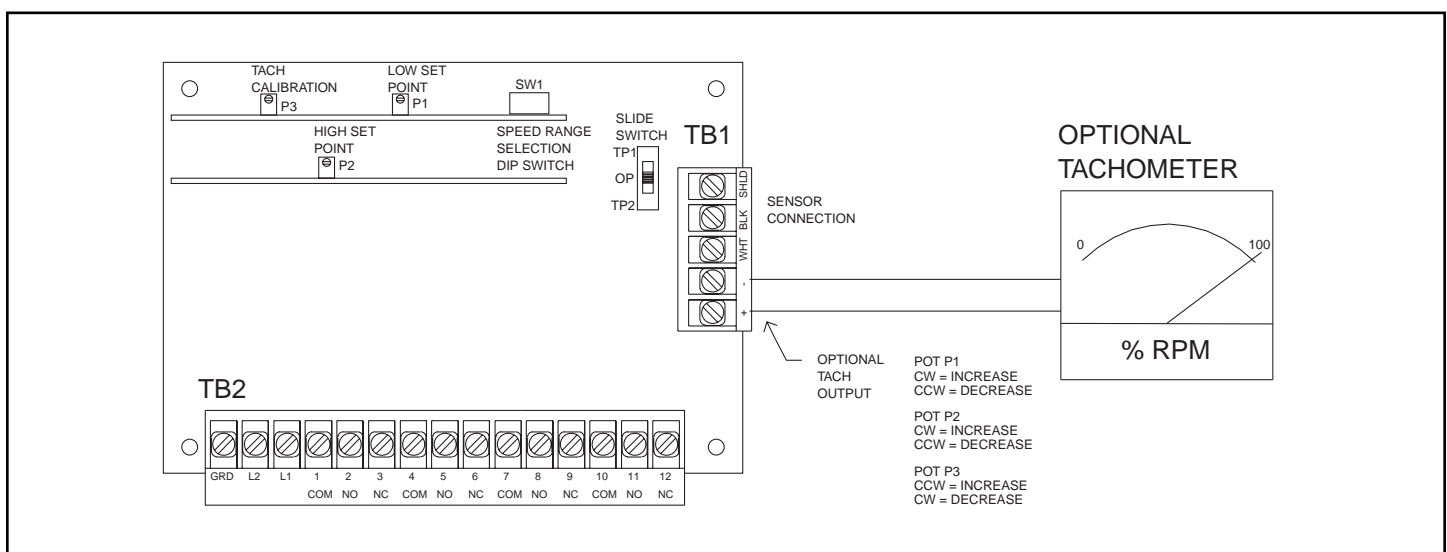

Figure 10

SPARE PARTS LIST

Part No.	Description
1142	A2000 Power Supply Circuit Board Without Relays
1325	Low Set Point Circuit Board
1350	High Set Point Circuit Board
1129	Standard Sensor With 10' Cable
1130	Standard Sensor Mounting Bracket With Jam Nuts
1132	Explosion Proof Sensor With 10' Cable
1134	Explosion Proof Sensor Mounting Bracket
1136	4" Magnet Disc
1320	Relay DPDT - 10 AMP @ 120 VAC

LIMITED WARRANTY

Process Control Systems, Inc. will repair or replace, at their option, F.O.B. factory, any part or unit which proves to be defective in material or workmanship within five years of purchase date, provided that part of the unit was installed and operated as recommended, to be established by examination of the part or unit at the factory. Goods returned under warranty must be shipped prepaid to the factory and accompanied by the serial number, description of defect, order number and date of purchase.

This warranty shall not apply to any Maxigard™ product which shall have been repaired or altered outside of the Process Control Systems factory or has been subject to misuse, negligence or accident.

Process Control Systems, Inc. warrants its products, but not their application, and shall not be liable for any incidental or consequential damages incurred through the use or loss of use of a Process Control Systems product. No representatives or other person is authorized or permitted to make any warranty or assume for this company any liability not strictly in accordance with this guarantee.

There is no further warranty either expressed or implied beyond that set forth herein.