



PROCESS CONTROL SYSTEMS, INC.

327 LAKE HAZELTINE DRIVE, CHASKA, MN 55318

952-361-3026

(Fax) 952-368-4129

800-328-0738

MAXIGARD™



A5000GEC-DC ZERO SPEED SWITCH 9-36 VDC

Description

The MAXIGARD™ A5000GEC-DC zero speed switch is designed to monitor the starting and stopping of critical rotating shafts. Maxigard™ products are manufactured to monitor material handling and process equipment in harsh industrial applications.

Principle of Operation

The A5000GEC-DC zero speed switch has a non-contact sensor and is supplied with a magnetic target. The sensor signal is not impaired by the buildup of dust or any other foreign material on the magnetic target or sensor. This switch is designed to detect zero speed (speeds less than 1 RPM) of the monitored shaft.

The A5000GEC-DC has one set of relay contacts. The relay is energized as soon as one magnet passes in front of the sensor and remains energized until the monitored shaft speed drops below 1 RPM for more than approximately 3.8 seconds. The relay re-energizes as soon as the monitored shaft starts to rotate and one magnet passes in front of the sensor. The switch is designed fail safe and in the event of a power failure or loss of signal the relay will de-energize.

.....

Components

.....
THE A5000GEC-DC ZERO SPEED SWITCH INCLUDES:

- • • • • ● 4" MAGNETIC DISC (OTHER OPTIONAL TARGETS AVAILABLE)
- • • • • ● SENSOR SELF CONTAINED IN CAST ALUMINUM HOUSING WITH CIRCUIT & RELAY
- • • • • ● MOUNTING HARDWARE



CALL TOLL FREE 800-328-0738

www.maxigard.com

E-mail: techsupport@maxigard.com

1.0 Magnetic Disc

- 1.1 The end of the shaft to be monitored should be flat to prevent excessive disc wobble.
- 1.2 Center drill and tap the shaft end. (Suggested #21 drill and #10-32NF tap). Bolt the magnetic disc to the end of the shaft. Use "Loc-tite" to keep the bolt and disc tight on the shaft.
(see figure 1A, page 3).

2.0 Magnetic Collar (optional)

- 2.1 Separate the two halves of the magnetic collar by loosening the cap screws holding the two halves together.
- 2.2 Place both halves of the magnetic collar around the shaft. Re-insert and tighten the cap screws making sure the collar is square to the shaft.
(see figure 1B, page 3).

NOTE

There will be a slight gap between the two halves after tightening. This gap will not affect the generated signal.

3.0 Mounting the Zero Speed Switch

- 3.1 Place the switch so the sensor is centered directly in front of the magnets in the disc or optional collar.
(see figure 1A & 1B, page 3).
- 3.2 The gap setting between the sensor and magnetic disc or magnetic collar should be approximately 1/8" - 3/4".

SENSING METHOD

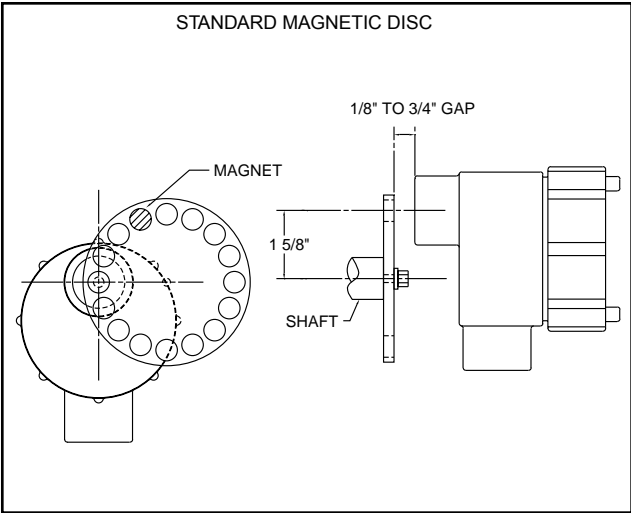

Figure 1A

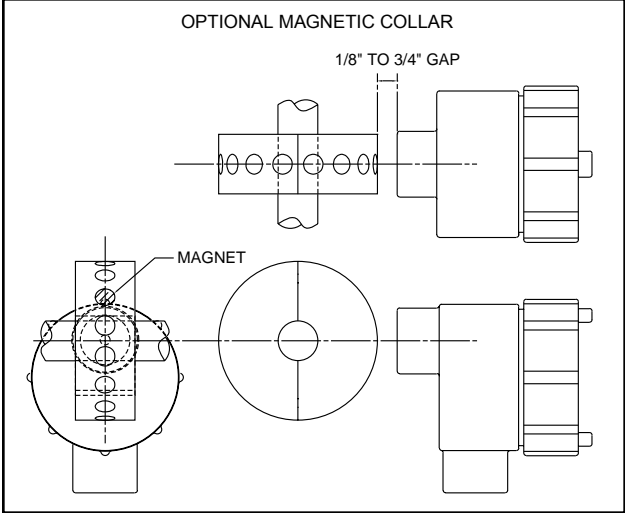

Figure 1B

DIMENSIONAL DATA

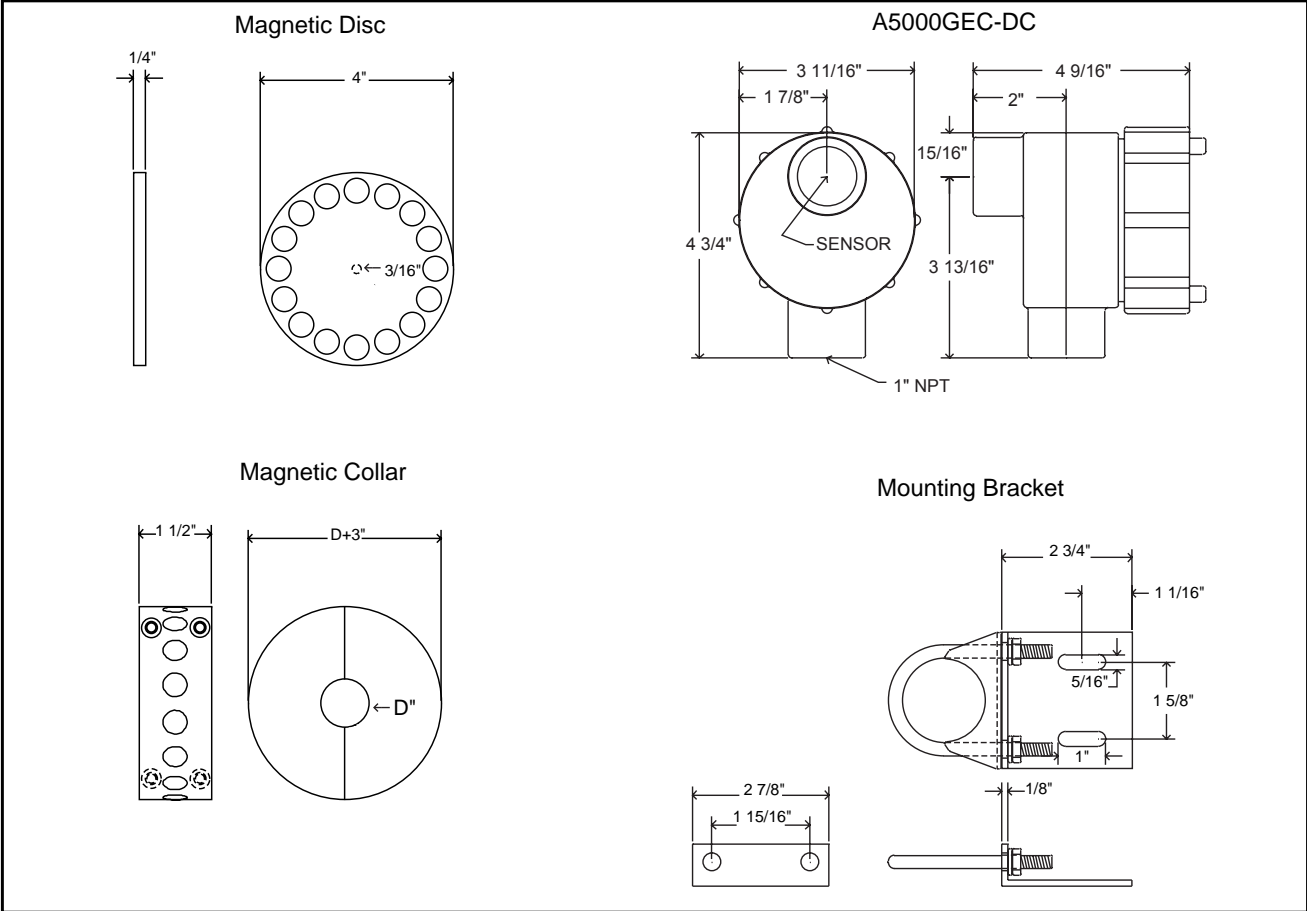

Figure 2

4.0 A5000GEC-DC Zero Speed Switch Housing

4.1 The A5000GEC-DC zero speed switch housing is certified for Class I, Div 1 & 2, Group D. Class II, Div. 1 & 2, Group E, F, & G. Class III. (see figure 2, page 3)

5.0 Wiring the A5000GEC-DC Zero Speed Switch

5.1 Power connections and relay connections to the A5000GEC-DC zero speed switch are shown on figure 3, page 4. Also, figure 4 & 5, page 5 & 6 show typical wiring diagrams.

WARNING

To avoid electrical shock disconnect all sources of power before wiring and observe voltage ratings of the zero speed switch.

5.2 Connect 9-36 VDC to L1 (red, +) and L2 (white, -). Connect the equipment safety ground to the grounding screw inside the A5000GEC-DC housing. (see figure 3, page 4)

5.3 Make relay connections to YELLOW, BROWN, and ORANGE wires.

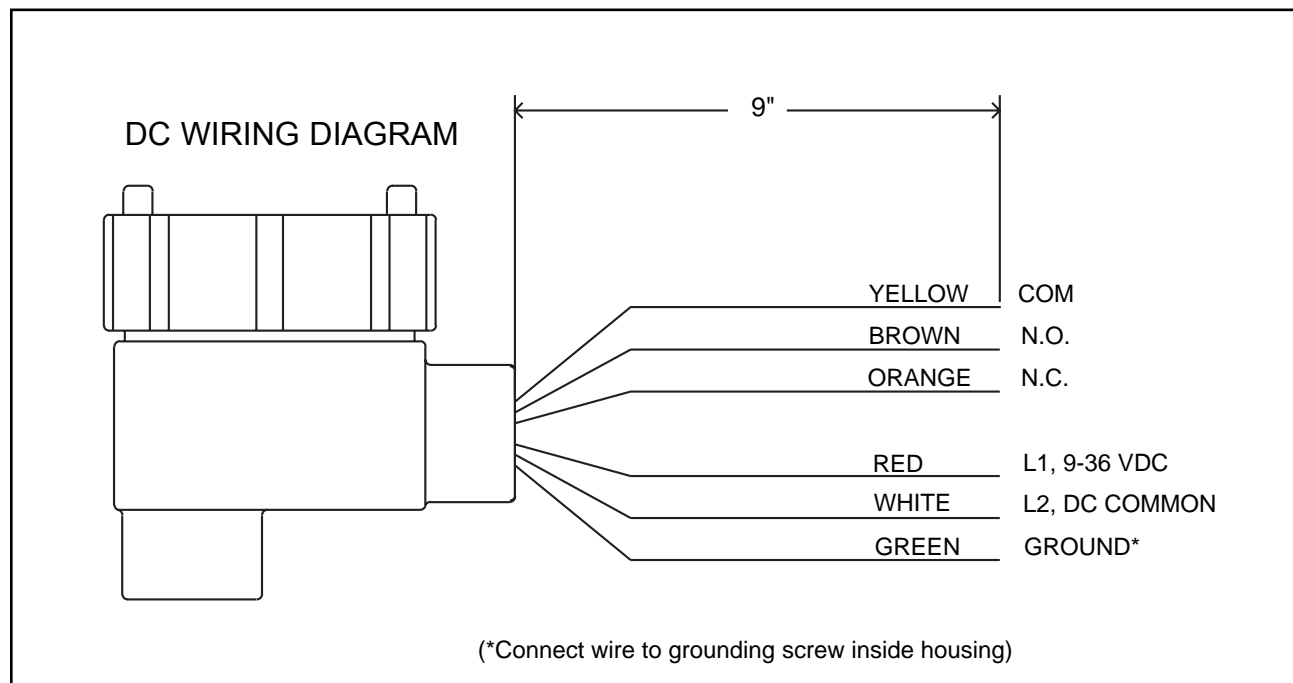

Figure 3

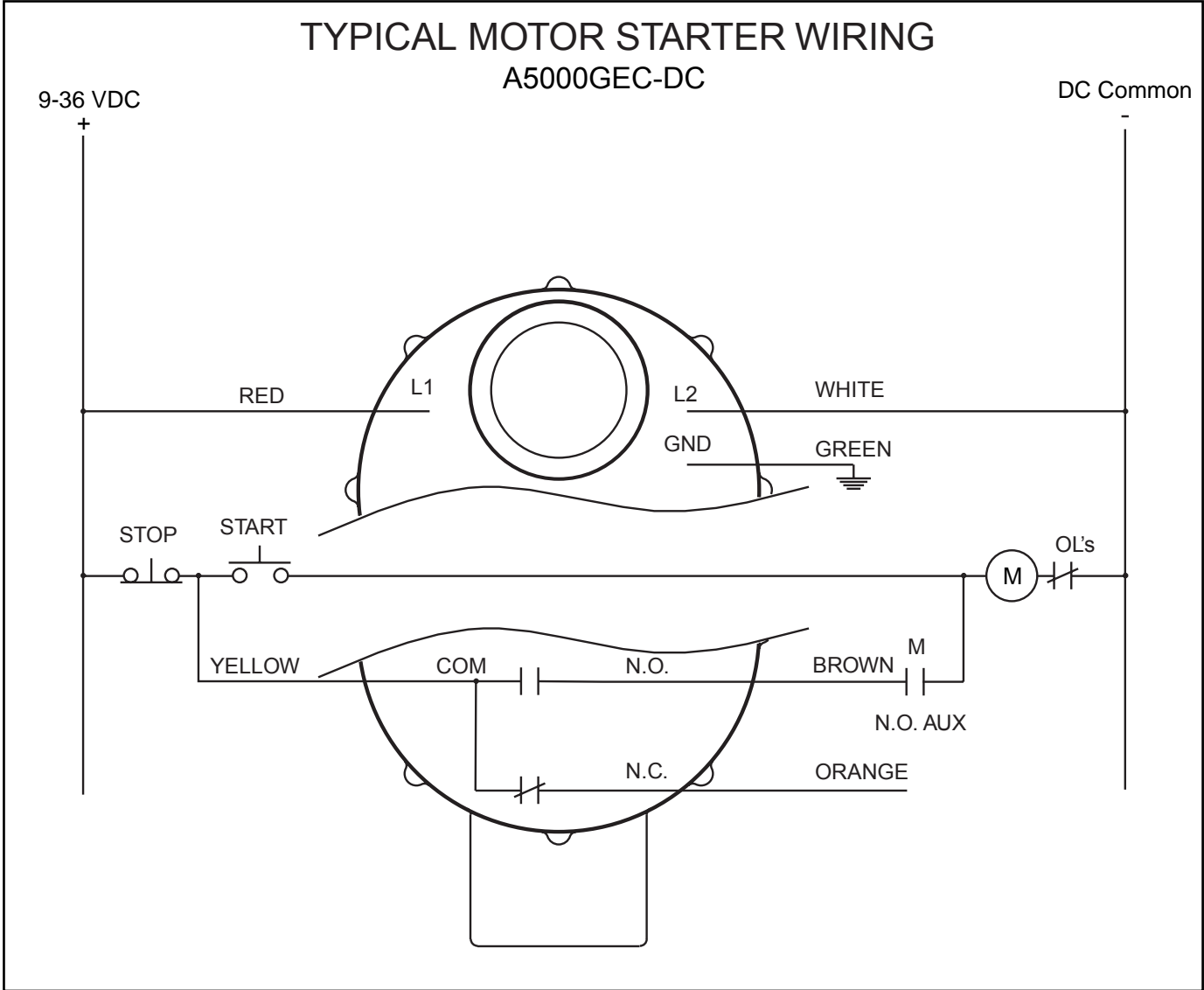

Figure 4

When DC power is applied to L1 and L2 the zero speed switch is powered on. When the start pushbutton is pressed the A5000GEC-DC zero speed switch N.O. (normally open) contact closes and the N.C. (normally closed) contact opens as soon as one magnet passes in front of the sensor. This completes the circuit around the start pushbutton sealing the motor starter on. The N.O. contact remains closed and the N.C. contact remains open until the monitored shaft speed drops below 1 RPM for approximately 3.8 seconds at which time the relay de-energizes and the motor starter drops out.

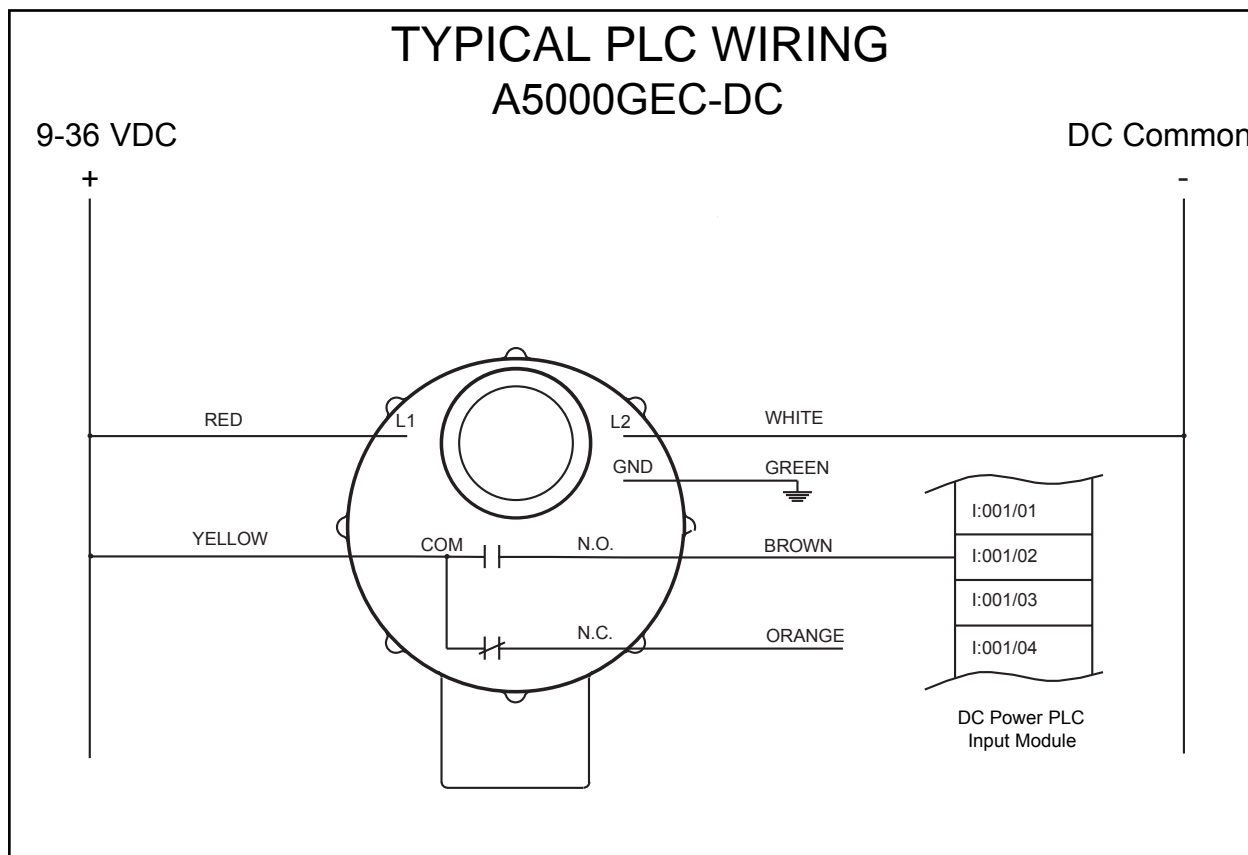
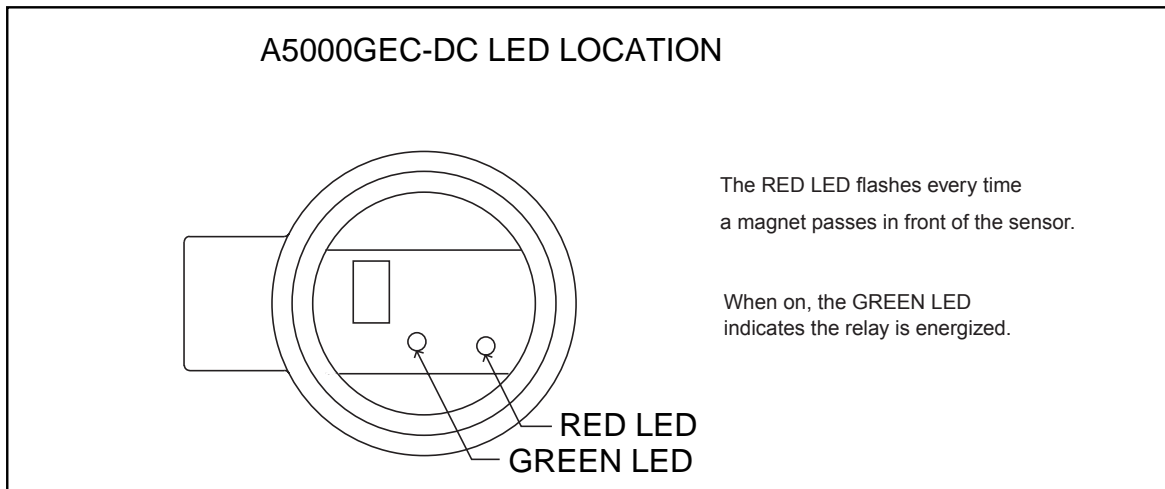

Figure 5

When DC power is applied to L1 and L2 the zero speed switch is powered on. The A5000GEC-DC zero speed switch N.O. (normally open) contact closes and the N.C. (normally closed) contact opens as soon as one magnet passes in front of the sensor. The N.O. contact remains closed and the N.C. contact remains open until the monitored shaft speed drops below 1 RPM for approximately 3.8 seconds.

6.0 Testing

- 6.1 Confirm proper mounting and electrical connections as described in sections 3 and 5.
- 6.2 Remove the back cover of the switch housing and locate the RED and GREEN LED's on the circuit board.



- 6.3 Start the monitored machine and run at normal speed with DC power connected to the switch.

WARNING

Proceed with caution when power is applied to the switch and the back cover is removed. Stay clear of any moving machinery.

- 6.4 The RED LED should be flashing or appear "on" (steady) if the shaft is turning fast. This indicates the speed switch sensor is properly aligned with the magnetic target.
- 6.5 The GREEN LED should be on steady indicating the monitored shaft is rotating. The switch relay is energized when the GREEN LED is on. The GREEN LED shuts off approximately 3.8 seconds after the monitored shaft stops turning.

NOTE

The RED LED will remain on if a magnet stops in front of the sensor. The switch relay will still de-energize as long as the shaft stops for more than 3.8 seconds.

SPARE PARTS LIST

Part No.	Description
1213GEC-DC	A5000GEC-DC, without Disc and Bracket
1217	Mounting Bracket
1136	Magnetic Disc 4"/ 16 Magnets
1378	Magnetic Disc 8"/ 32 Magnets
1705	Magnetic Disc 8"/ 48 Magnets

LIMITED WARRANTY

Process Control Systems, Inc. will repair or replace, at their option, F.O.B. factory, any part or unit which proves to be defective in material or workmanship within five years of purchase date, provided that part of the unit was installed and operated as recommended, to be established by examination of the part or unit at the factory. Goods returned under warranty must be shipped prepaid to the factory and accompanied by the serial number, description of defect, order number and date of purchase.

This warranty shall not apply to any Maxigard™ product which shall have been repaired or altered outside of the Process Control Systems factory or has been subject to misuse, negligence or accident.

Process Control Systems, Inc. warrants its products, but not their application, and shall not be liable for any incidental or consequential damages incurred through the use or loss of use of a Process Control Systems product. No representatives or other person is authorized or permitted to make any warranty or assume for this company any liability not strictly in accordance with this guarantee.

There is no further warranty either expressed or implied beyond that set forth herein.